



PAL® LIFT SERIES

OWNER'S MANUAL & MAINTENANCE PROCEDURES



S.R. SMITH, LLC
CORPORATE HEADQUARTERS
P.O. Box 400 • 1017 S.W. Berg Parkway
Canby, Oregon 97013 USA
Phone (503) 266 2231 • Fax (503) 266 4334
www.srsmith.com

DECK PROFILE SHEET CONFIRMATION

Aquatic access lifts are application specific. A completed Deck Profile Sheet helps to ensure the lift purchased for the application will work in accordance to ADA guidelines. S.R. Smith reviews all submitted Deck Profile Sheets as a service to our customers, free of charge. Before installing the pool lift, the installer must review and confirm the information provided on the Deck Profile Sheet. If the description of the application does not match the installation site, a new Deck Profile Sheet must be completed and submitted to S.R. Smith.

NOTE: FAILURE TO COMPLETE AN ACCURATE DECK PROFILE SHEET MAY RESULT IN THE LIFT NOT MEETING ADA COMPLIANCE GUIDELINES.

To complete the Deck Profile Sheet online, visit www.srsmith.com/liftprofile, contact Customer Service at (800) 824-4387 or email customercare@srsmith.com.

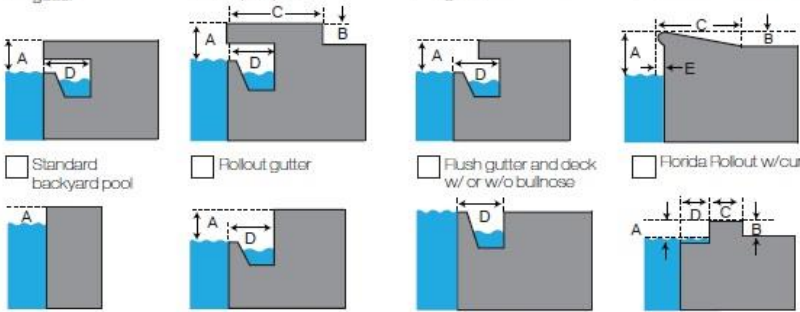
		deck profile sheet POOL LIFT*	
<small>*Deck profile sheet must accompany your pool lift order</small>			
1. Preferred Lift: <input type="checkbox"/> PAL <input type="checkbox"/> PAL2 <input type="checkbox"/> Splash! <input type="checkbox"/> Splash! 300 <input type="checkbox"/> aXs <input type="checkbox"/> multiLift <input type="checkbox"/> ML300			
2. Gutter Configuration:			
<input type="checkbox"/> Fully recessed gutter <input type="checkbox"/> Fully recessed gutter w/parapet <input type="checkbox"/> Partially recessed gutter <input type="checkbox"/> Bull Nose Coping			
			
<input type="checkbox"/> Standard backyard pool <input type="checkbox"/> Rollout gutter <input type="checkbox"/> Flush gutter and deck w/ or w/o bullnose <input type="checkbox"/> Florida Rollout w/curb			
<small>If none of the images above match your gutter configuration, please draw the shape on a separate piece of paper and attach.</small>			
3. Facility Type (check one): <input type="checkbox"/> Health Club <input type="checkbox"/> Hospitality <input type="checkbox"/> Public Pool <input type="checkbox"/> Residential <input type="checkbox"/> Commercial			
4. Deck (check one): <input type="checkbox"/> New Construction <input type="checkbox"/> Pre-existing			
5. Deck Material (check one): <input type="checkbox"/> Concrete <input type="checkbox"/> Pavers			
6. Distance from pool deck to water line (A): _____		<input type="checkbox"/> Check this box to confirm that you have verified the location of the lift will meet the ADA Clear Deck Space Requirement (1009.2.3):	
7. Height of curb (B): _____		<small>"On the side of the seat opposite the water, a clear deck space shall be provided parallel with the seat. The space shall be 36" wide minimum and shall extend forward 48" minimum from a line located 12" behind the rear edge of the seat."</small>	
8. Width of curb (C): _____			
9. Width of gutter (D): _____			
10. Bull Nose Radius (E): _____			
11. Decorative stone setback: _____			
12. Is your pool located on the ground level? <input type="checkbox"/> Yes <input type="checkbox"/> No			
<small>Note: Pool lifts are application specific. Please provide accurate measurements for your pool in the space provided. S.R. Smith will confirm that the lift selected will meet the location and installation requirements based on the ADA Design Standards (2010) or suggest an alternative lift that will meet the requirements. S.R. Smith bears no responsibility due to misapplication of a lift without a completed Deck Profile Sheet on record.</small>			
Fax this completed form to 503.266.4334, email to lifts@srsmith.com, or complete the form online at www.srsmith.com/liftprofile. Call toll free 800.824.4387			
Name of Distributor Lift Will Be Purchased From _____			City _____
			State _____
Your Name: _____		Email _____	Phone _____
Property or Project Name _____		PO Number _____	
S.R. Smith Use Only			
APPROVAL# _____			
<input type="radio"/> PAL <input type="radio"/> PAL HI/LO <input type="radio"/> PAL SPA <input type="radio"/> PAL2			
<input type="radio"/> SPLASH <input type="radio"/> SPLASH HI/LO <input type="radio"/> SPLASH ER <input type="radio"/> SPLASH ER HI/LO <input type="radio"/> SPLASH SPA			
<input type="radio"/> SPLASH 300 <input type="radio"/> SPLASH W/ROUND POST <input type="radio"/> AXS <input type="radio"/> MULTILIFT <input type="radio"/> ML300			

SF-720-003

8/2015

TABLE OF CONTENTS

PAL/200-0000/EU/K - PAL Hi-Lo/250-0000/EU/K - PAL Spa/275-0000/EU/K

DECK PROFILE SHEET CONFIRMATION	2
INTRODUCTION.....	3
WARNINGS AND SAFETY SUMMARY	4
PRODUCT OVERVIEW	6
PAL – Portable Aquatic Lift - PRODUCT COMPONENTS	7
UNPACKING & ASSEMBLY INSTRUCTIONS.....	13
USING THE PAL – Portable Aquatic Lift	17
POSITIONING.....	18
TRANSFERRING	18
STANDARD ACCESSORIES/OPTIONAL ACCESSORIES	19
MAINTENANCE and CLEANSING	19
TROUBLE SHOOTING	20
LONG-TERM STORAGE	21
CUSTOMER CARE.....	21
WARRANTY INFORMATION	22
SPECIFICATIONS	23
2. Actuator	23
3. Motor.....	23
4. Battery	23
5. Range of Motion	23
6. Noise.....	23
7. Materials and Finish	23
PART LIST (PAL).....	24
PART LIST (PAL Hi/Lo and SPA)	25

READ THESE INSTRUCTIONS IN THEIR ENTIRETY BEFORE BEGINNING INSTALLATION

INTRODUCTION

The purpose of this document is to provide information relating to the safe operation, care, and maintenance of the **PAL/200-0000/EU/K - PAL Hi-Lo/250-0000/EU/K - PAL Spa/275-0000/EU/K**

Read and Follow all User Instructions listed in the Owner’s Manual before use
Read and Follow all Caution and Warning labels located on the lift before use

INTENDED LIFT USER

All of S.R. Smith’s lifts have been designed to assist anyone who has problems entering or exiting a swimming pool or spa - the only restriction is that the User does not exceed the weight limit of the product (300 lb/136 kg). It is the responsibility of the lift Owner to ensure that the correct safety procedures have been put in place and a risk assessment carried out. The unit must be correctly positioned with the stabilizer arms fully extended and the rear brakes fully applied prior to use. If a User is mentally challenged or has severe physical disabilities these issues must be taken into account to determine the number of persons required to complete the transfer onto the seat and the number of persons required to be in the water, ready to receive the User. The seat belt must be attached to the seat and fully fastened and used during each transfer.

Our goal is to provide our customers with the most advanced and innovative designs offering exceptional quality at affordable prices. All of our lifts meet the specifications set forth by the Access Board - ADAAG 2004 (US only), Medical Device Directive, 93/42/EEC, RoHS2 Directive 2011/65/EU, EN 50581:2012

Model / Product No. _____
Product Name



S.R. Smith, LLC

PO Box 400
1017 SW Berg Parkway
Canby, Oregon 97013 USA
Phone: 503-266-2231
Fax: 503-266-4334
www.srsmith.com
Made in USA

SN S

EC REP

QNET BV
Kanstraat 19
NL-5076 NP Haaren
The Netherlands
qnet@ce-mark.com
qnet@ce-authorizedrepresentative.eu



24 VDC

and ISO10535:2006 including repeating the lifting cycle of the hoist (lift) for a total of 11,000 cycles. The lift system and AC powered battery charger complies with EN60601-1-2, 2007/03.

US Patent No. 5,790,995

PAL - Portable Aquatic Lift, the PAL logo and LiftOperator are registered trademarks of S.R. Smith, LLC



WARNINGS AND SAFETY SUMMARY

DANGER – FAILURE TO FOLLOW THESE WARNINGS, INSTRUCTIONS AND THE OWNER'S MANUAL MAY RESULT IN SERIOUS INJURY OR DEATH

WARNING

- **ADULT USE ONLY** – Use by children with adult supervision only. Only persons healthy enough for water activities should use the PAL. Users should consult with their physician to determine if water activities are appropriate for the User.
- Seat belt is to be used at all times during user transfer.
- Lift must be positioned on firm level ground not to exceed a slope of 2°.
- **NO JUMPING/DIVING/CLIMBING** – Do not jump/dive from or climb on lift.
- **TIP OVER HAZARD** – Stabilizing arms must be fully extended before each use and must be used at all times when a user is seated. The lift may not be used without the stabilizing arms fully extended. Never attempt to retract the stabilizer arms when the lift is in use. Do not reposition the lift when lift is in use.
- **UNINTENDED MOVEMENT/TIP OVER HAZARD** – Rear wheels must be locked at all times while the lift is in use. Ensure proper ballast weights are installed in base before each use.
- **TIP OVER HAZARD** – Do not use the lift to transport a user from place to place.
- **TIP OVER HAZARD** – Limit for use is ONE PERSON weighing less than the maximum weight limit of - 300lbs (136kg). Use only for transfer of user not as a hoist or crane.
- **PINCH/CRUSH HAZARD** – Always keep hands and fingers clear of lift arms during use.
- The battery must be completely removed from lift and located away from pool deck for charging.

CAUTION

- **BATTERY CHARGE LEVEL** – Check Battery Level before each use. Battery must show GREEN >50% charge level before use. When YELLOW <50% charge level is shown the battery must be fully charged before use. When RED <25% charge level is shown the lift must not be used and the battery must be fully charged before use.
- **DAMAGE MAY RESULT** – Do not use the seat or seat frame to move or position the PAL.
- **DAMAGE MAY RESULT** - Do not allow excessive moisture to collect in the battery case, it can affect battery and lift performance and could lead to battery failure and/or the lift failing to operate.

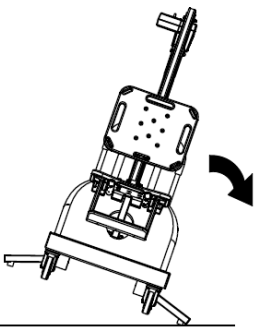

! WARNING
TIPPING HAZARDS

- STABILIZING ARMS MUST BE FULLY EXTENDED BEFORE EACH USE AND MUST BE USED AT ALL TIMES WHEN A USER IS SEATED.
- THE LIFT MAY NOT BE USED WITHOUT THE STABILIZING ARMS FULLY EXTENDED.
- NEVER ATTEMPT TO RETRACT THE STABILIZING ARMS WHEN THE LIFT IS IN USE.
- DO NOT REPOSITION THE LIFT WHEN THE LIFT IS IN USE.
- USE ON A FIRM LEVEL SURFACE NOT TO EXCEED A 2° SLOPE.
- ENSURE PROPER BALAST WEIGHTS ARE INSTALLED IN LIFT BASE BEFORE EACH USE.
- DO NOT USE THE LIFT TO TRANSPORT USERS FROM PLACE TO PLACE.
- LIMIT FOR USE IS ONE PERSON WEIGHING LESS THAN THE MAXIMUM WEIGHT LIMIT OF 300 LB (136 kg).

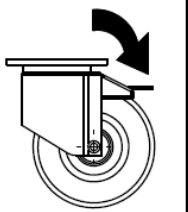

! WARNING

- REAR WHEELS MUST BE LOCKED AT ALL TIMES WHILE THE LIFT IS IN USE.
- FAILURE TO LOCK WHEELS MAY RESULT IN UNINTENDED MOTION OR TIPPING.

! WARNING
TIPPING HAZARD

LIMIT FOR USE IS ONE PERSON WEIGHING LESS THAN THE MAXIMUM WEIGHT LIMIT OF 300 lbs (136 kg)



! WARNING
Pinch Points.
Moving part can crush or cut.
KEEP CLEAR.

ADA GUIDELINE SUMMARY* (USA Only)

1009.2.1 Pool Lift Location

Pool lift shall be located where the water level does not exceed 48". If entire pool water level exceeds 48", place pool lift where convenient.

1009.2.2 Seat Location

In the raised position, the centerline of the seat shall be located over the deck a minimum of 16" from the edge of the pool.

1009.2.3 Clear Deck Space

On the side of the seat opposite the water; a clear deck space shall be provided parallel with the seat. The space shall be 36" wide minimum and shall extend forward 48" minimum from a line located 12" behind the rear edge of the seat.

1009.2.4 Seat Height

The lift shall stop at 16" – 19" measured from the deck to the top of the seat surface when in the loading position.

1009.2.8 Submerged Depth

The lift shall submerge the seat a minimum of 18" below the stationary water level.

*Compliance with ADA is the responsibility of the pool owner. Visit www.ada.gov for complete guidelines.

THE PAL - PORTABLE AQUATIC LIFT



PRODUCT OVERVIEW

The PAL-Portable Aquatic Lift is a portable lift system designed so that individuals with disabilities and mobility impairments can have universal access to any type of swimming pool or spa. The PAL is powered by a 24 volt rechargeable battery operated by a screw-driven electronic actuator that provides the lifting and turning motions. S.R. Smith has designed the safest possible lift system, following all instructions in the owner's manual, and all product labels is necessary to achieve safe, reliable and proper performance of the lift and avoid injury. This design ensures consistent safe operation and minimizes service problems. The PAL is designed to provide flexibility for aquatic facilities seeking to provide access to more than one pool or spa, or to accommodate a user's desire to enter a single pool in multiple locations. The PAL is available in a Hi-Lo version for facilities with both in-ground pools and above-ground spas, as well as a Spa version for above-ground pools and spas. The maximum lift capacity for all PAL models is 300 lb/136 kg. The PAL lift shall be used on rigid level pool deck surfaces not to exceed a slope of 2°. Only persons healthy enough for water activities should use the PAL. Users should consult with their physician to determine if water activities are appropriate for the User.

WARNING: The PAL lift is designed to transfer (lift) users from the deck surrounding the swimming pool/spa into the water and back again. It is not designed to transport users from place to place. Serious injury can result if the lift is moved while a user is in the seat.

PAL – Portable Aquatic Lift - PRODUCT COMPONENTS

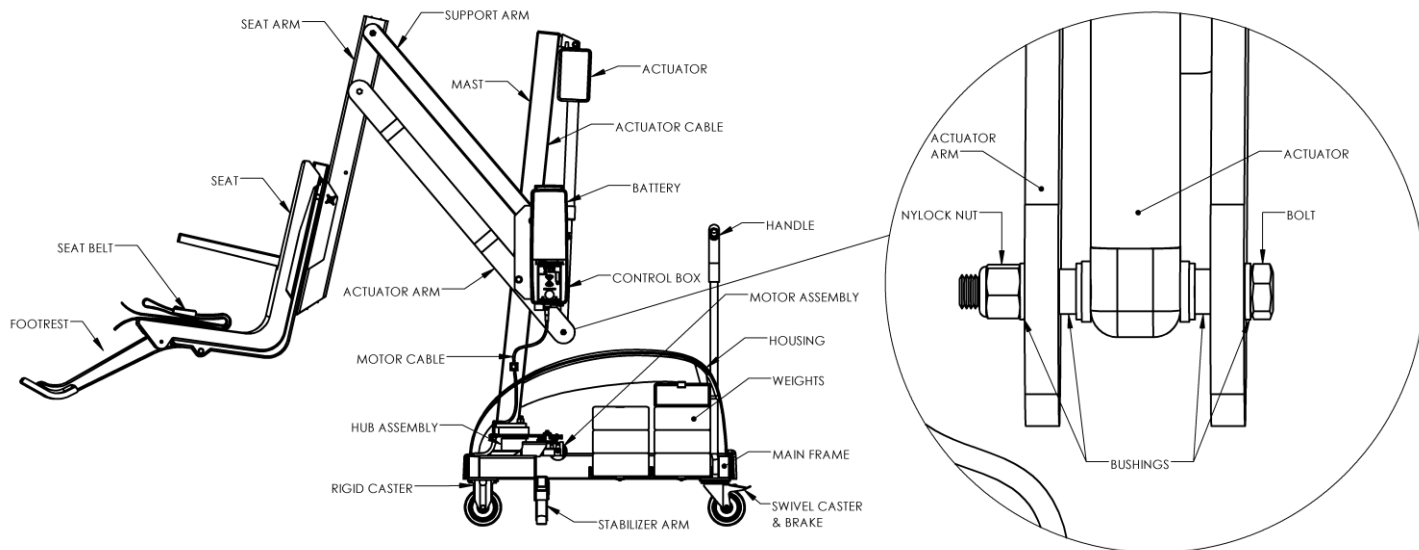

COMPONENT DESCRIPTION

The Base Assembly is made up of several components as described below:

Wheels - Front wheels are rigid and back wheels swivel to facilitate movement. Both back wheels can and must be locked to prevent movement during transfer to and from the pool.

WARNING: Failure to lock both rear wheels during transfer could cause lift movement and may result in injury. Both rear wheels must be locked whenever the lift is positioned for use. Do not unlock rear wheels during transfer as the lift could move and may result in injury.

Main Frame - The rectangular piece that is fixed to the wheels - the main frame is made up of several components:

Stabilizing Arms - Two arms pull out to level the lift and must always be fully extended when the lift is in use.

WARNING: Failure to fully extend both stabilizer arms during transfer could cause lift movement and may result in injury. Both stabilizing arms must be fully extended whenever the lift is positioned for use. Do not retract stabilizing arms during transfer as the lift could move and may result in injury.

Housing - ABS plastic cover shields main frame components from weather. The housing needs to be in place prior to installing mast assembly.

Handle - Connects to Main Frame through openings in housing.

LiftOperator Control Box - The LiftOperator is available with an optional Activation Key feature that provides a higher level of security by allowing control operation only with the use of the activation key. The unit controls all lift operations identical to the user hand set. Three cables connect to the bottom of the Control Box to enable operation of the lift. The largest connector is for the hand control. Connector # 1 is for the motor cable (red stripe). Connector # 2 is for the actuator cable (green stripe).



CONNECTOR 1
(MOTOR CABLE)

CONNECTOR 2
(ACTUATOR CABLE)

Touchpad Control –

The touchpad control arrow keys can be used in the event that the hand control is out of reach or fails. Simply press and hold the arrow for the desired action for one movement at a time – Up, Down, Left, Right Releasing the Arrow stops movement.

Battery Level LED Indicators –

The Battery Level LED Indicators show battery charge levels. The LED's will illuminate when either the touchpad control or the hand control is activated and will stay lit for 10 seconds. At greater than 50% the LED glows Green, at less than 50% the LED glows Amber, and less than 25% the LED glows red and indicates the battery requires charging. If the less than 25% LED glows red, do not operate the lift. Remove the battery and fully charge before use.

Service Required LED –

The Service Required LED will illuminate when the battery pack has been removed/replaced 120 times - approximately once every 4 months. This indicates that required maintenance for the lift must be completed. Please see the maintenance section of the Lift Owner's Manual for the requirements. The Service Required LED can be reset by inserting a standard FAT-formatted USB mass storage device (not included) into the USB Port on the bottom of the controller. **When the service light is illuminated the lift must not be used until required maintenance is performed.**

Emergency Stop Button –

In the event of an emergency, or if you need to stop lift movement immediately, pressing the Emergency Stop Button (red button on the control) will stop all lift movement. At the same time an audible alert will sound for 10 sec. then pause for 5 sec. and then the sequence will repeat until the button is reset by turning it in the direction of the arrows on the button (clockwise). The Emergency Alert LED will also flash Red when the button is pressed and will remain flashing until the button is reset.

The Emergency Alert (audible and LED) can be activated by pressing any two buttons on the hand control at the same time (provided with the lift). This will stop all lift movement and activate the audible alert and the Red LED will flash. Once both buttons are released, the lift will return to normal operation and the emergency audible alert will silence.

USB Port –

The LiftOperator control contains a USB port that is used to download the performance log of the lift. Using any standard FAT file formatted USB memory stick (widely available through retail outlets) insert the stick into the slot on the bottom of the control on the far right hand side. Press any of the touchpad control arrows; all three of the Battery Level LED's will flash. During downloading the Green greater than 50% Battery Level LED will flash. If the unit has a problem downloading the performance log the Red less than 25% LED will flash. Remove the USB from the port and re-insert it. If the Red 25% LED flashes again, confirm that the USB you are using is FAT file formatted. The information from the USB can be downloaded to a PC for review and/or copied to a spread sheet. The performance log will retain approximately 7,600 events. Once the file is full it will remove the oldest event and replace with the newest.

After the summary data, the events are shown with the oldest first. The first column is the time in seconds from that last event. The second column is the text describing the event. The third column is duration of the activity noted in seconds.

An example of a short log file:

<u>Activity</u>	<u>Description</u>
dev_id_upper,0	Programing data
dev_id_lower,1	Programing data
fw_rev,90	Firmware rev.
batt_volt_float,24929	Non-loaded battery voltage in millivolts
batt_volt_load,21487	Loaded battery voltage in millivolts
batt_capacity,99	Estimated battery capacity in %
charge_starts,8	Number of times charging was attempted
charge_completes,1	Number of times charging was finished successfully
0,power_on,1	Connecting Battery Pack
0,key_enable,	Inserting Activation Key
2,alert_pressed,	Emergency Button pressed
3,alert_released,	Emergency Button released
8,lift_up,2	Lift movement - up
5,lift_down,2	Lift movement - down
11,lift_up,2	
4,turn_left,2	Lift movement - turn left
3,turn_right,1	Lift movement - turn right
308,key_disable,	Removing Activation Key
3,log_write,	USB File Download

Battery Pack - The battery pack is located on top of the Control Box and is removable.

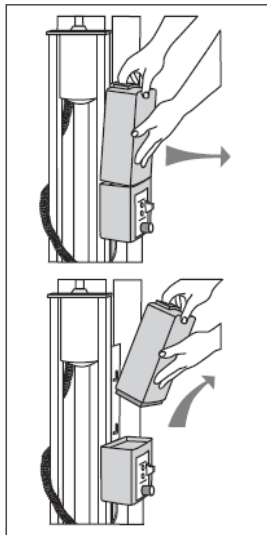

To remove - pull the battery pack away from the mounting plate so that the latch on the battery pack clears the side tabs on the mounting plate - then lift the battery pack up and away from the Control Box.

To replace - align the battery pack with the mounting plate so that the latch will drop over the center tab and that the bottom of the battery pack will fit in the recessed area on top of the Control Box. Lower the battery pack in place so that the latch is fully captured by the mounting plate and the battery pack drops fully seated onto the Control Box.

The battery must be completely removed from the lift and located away from the pool deck for charging.

The battery pack should be charged daily. Do not allow battery to fully discharge, as it will shorten battery life.

The battery pack has an LED indicator near the plug-in-port. It will glow Red when first plugged into the transformer. If the LED remains Red this indicates the battery pack needs charging. When fully charged the LED will glow Green. If the battery is fully charged and is plugged into the transformer the LED will glow Red for approximately 10 sec. then glow Green. If the LED flashes Red when plugged in this indicates a fault with the battery and indicates the battery pack should be replaced. All batteries are inspected prior to shipment. See warranty policy regarding battery replacement for problems after sale. Batteries have a normal lifespan of between 2-3 years, depending on use and care. A fully charged battery will provide approximately 30 to 40-lifting cycles, depending on the weight of the users. Prior to use the battery charge level should be checked by observing the LED indicator above the charger plug to ensure sufficient charge level. The charger must be connected to the battery to view the LED.



It is not necessary to fully discharge the battery prior to charging. Battery should be charged daily and cannot be overcharged. It takes up to twelve hours to fully charge depending upon battery usage. Do not allow battery to fully discharge, as it will shorten battery life.

Do not drop the battery, as it could cause the unit to fail. If the battery case is cracked do not use and replace the battery. During temperature extremes beyond the range of 41 F (5 C) to 104 F (40 C) remove battery and place in a controlled environment or battery life may be shortened.

Battery Disposal - The batteries located inside the battery pack are recyclable and shall be disposed of in accordance with applicable local, state/provincial or federal/national regulations.

Locking Plate Assembly - The battery pack can be secured to the mounting plate using the provided lock plate assembly. To install open the lock plate so that the bottom tabs are moved close to one another to allow the lock plate to be inserted into the slots on the mounting plate secured to the lift. Close the lock plate assembly so that the tabs are captured by the slots. Insert a padlock (not provided) through the holes on the lock plate assembly to secure it.

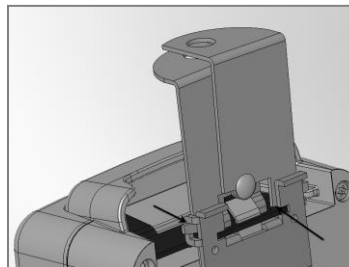
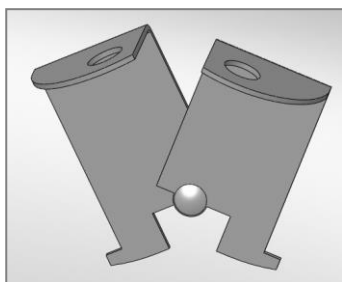

4-Button Hand Control

Console/Battery Cover - Keep the Console/Battery Cover installed at all times to prevent moisture from collecting on the Control Box and battery. Whenever the battery is removed for charging the Console/Battery Cover must be placed over the Control Box to protect the unit from the elements.

Hand Control - The four button unit controls all lift movements. The arrows indicate direction of movement. Control is fully waterproof and meets IP67 standards.



Mast - This vertical piece is bolted to the base assembly.

Actuator - Attached to mast, this part powers the up and down movements of the lift.

Rotation Motor Assembly - Consists of mounting plate, 24-volt motor, and small gear.

Hub Assembly - Consists of hub, bearings, shaft, large gear and mast mounting plate.

Horizontal Support Arms - These two support arms connect the mast to the seat support arm. The longer horizontal support arm (actuator arm) connects to the actuator and initiates lifting movements.

Seat Arm - Connects the seat to the horizontal support arms.

Seating System – The seat is manufactured from roto-molded plastic with a stainless steel frame.

The seat belt must be used during each use. The footrest is removable and will float upwards to prevent damage if the seat is lowered too far. It is recommended that the seat be rinsed off with fresh water between each use and cleansed daily with a disinfectant solution of 1:100 dilution of household bleach to fresh water and then rinsed with fresh water. In the event of a contamination incident such as patient/user excreta - cleanse seat and seatbelt immediately with the above disinfectant solution. Do not use the seat or seatbelt if it is damaged or becomes worn out.

Armrests are included as a standard item on all S.R. Smith lifts. The armrests are designed so they can be rotated up out of the way during transfer.

This lift seat assembly is designed to be used exclusively with S.R. Smith aquatic access lifts.

Counter Weights - The weights for the lift are located in the bottom of the pallet. Remove the restraining planks with a screwdriver to gain access.

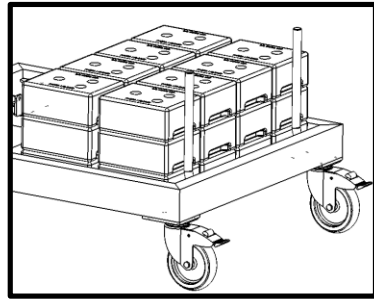

1.

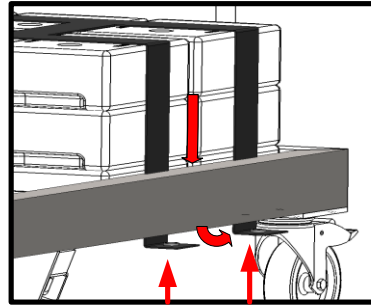

2.

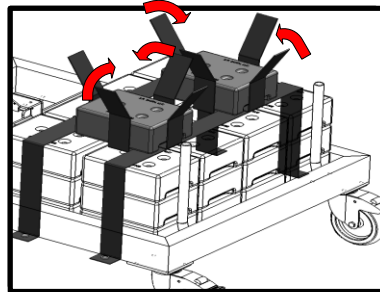

3.

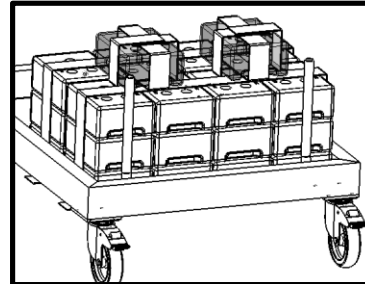

4.

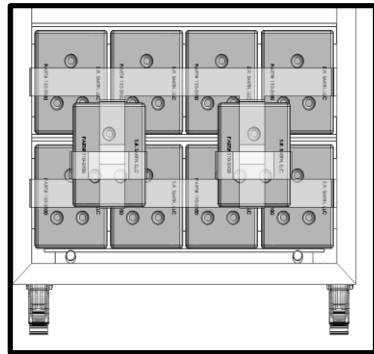

5.

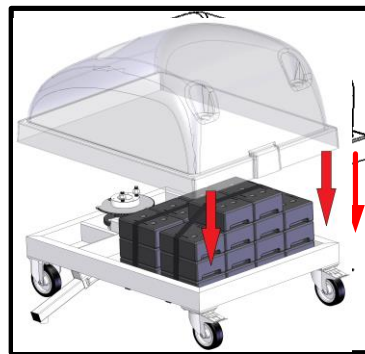

6.

Each weight is approximately 30 lb/13.6 kg. Use caution when lifting. There are finger holds on each weight to help handling.

Weights leave the factory in good condition; however, they may have shifted during shipping. Inspect the weights prior to installation to be sure the paint has not been scratched. Use the touch-up paint supplied to cover any scratches. The weights are cast iron - if the raw surface is exposed to the elements, it can rust which could stain the pool deck. Inspect the weight stack monthly for any scratches and touch up as required. Acrylic spray paint can be used in place of the touch up paint.

Place the weights onto the PAL frame as shown in the diagrams. Stack the weights so the feet on the bottom of the weight nest into the indentation on top.

With the weights in place, attach the restraining harness to the snaps underneath frame as shown in the diagrams. Assemble the rest of the PAL according to the instructions that follow.

CAUTION: The restraining harness must be correctly attached to frame. Failure to correctly attach the restraining harness to frame may result in the weights shifting during use.

UNPACKING & ASSEMBLY INSTRUCTIONS

REFER TO DIAGRAM (page 24) FOR PARTS IDENTIFICATION.

READ THESE INSTRUCTIONS IN THEIR ENTIRETY BEFORE UNCRATING PAL

Prior to opening pallet, inspect external condition for any visible damage. It is important that any damage be noted on the Bill of Lading. Immediately notify S.R. Smith or your Authorized Reseller of missing or damaged parts.

The PAL is shipped on a covered pallet and is VERY HEAVY. You will need the following tools for unpacking and assembly:

- 3/4" or 19mm socket wrench
- 9/16" or 14mm socket and 9/16" or 14mm wrench
- small flat blade screwdriver
- knife or cutters to cut shrink-wrap/bands.

Unpacking & Assembly Procedure for the PAL – Portable Aquatic Lift

1. Cut open enclosure bag at base of unit - carefully remove plastic.
2. Cut internal bands – remove mast assembly, seat assembly and housing. Lift assembly by mast and seat arm. Do not lift mast assembly by actuator as this could damage the actuator.
3. Remove accessory box.
4. Remove handle from frame.
5. Remove main frame from pallet. Position main frame close to pallet and lock both rear wheels.
6. Remove the housing from the main frame.
7. Remove bracing from pallet to allow access to counterweights and carefully transfer 26 counterweights from pallet and attach restraining strap following instructions on pages 12 and 13.
8. Place housing back onto the frame.
9. Place handle over the posts on the frame and through the housing.
10. Remove 2 lock nuts and washers from mast mounting hub on base assembly.

11. Position mast assembly through housing and attach to studs located on base assembly with lock nuts and washers. Fully tighten with 3/4" or 19mm socket wrench.

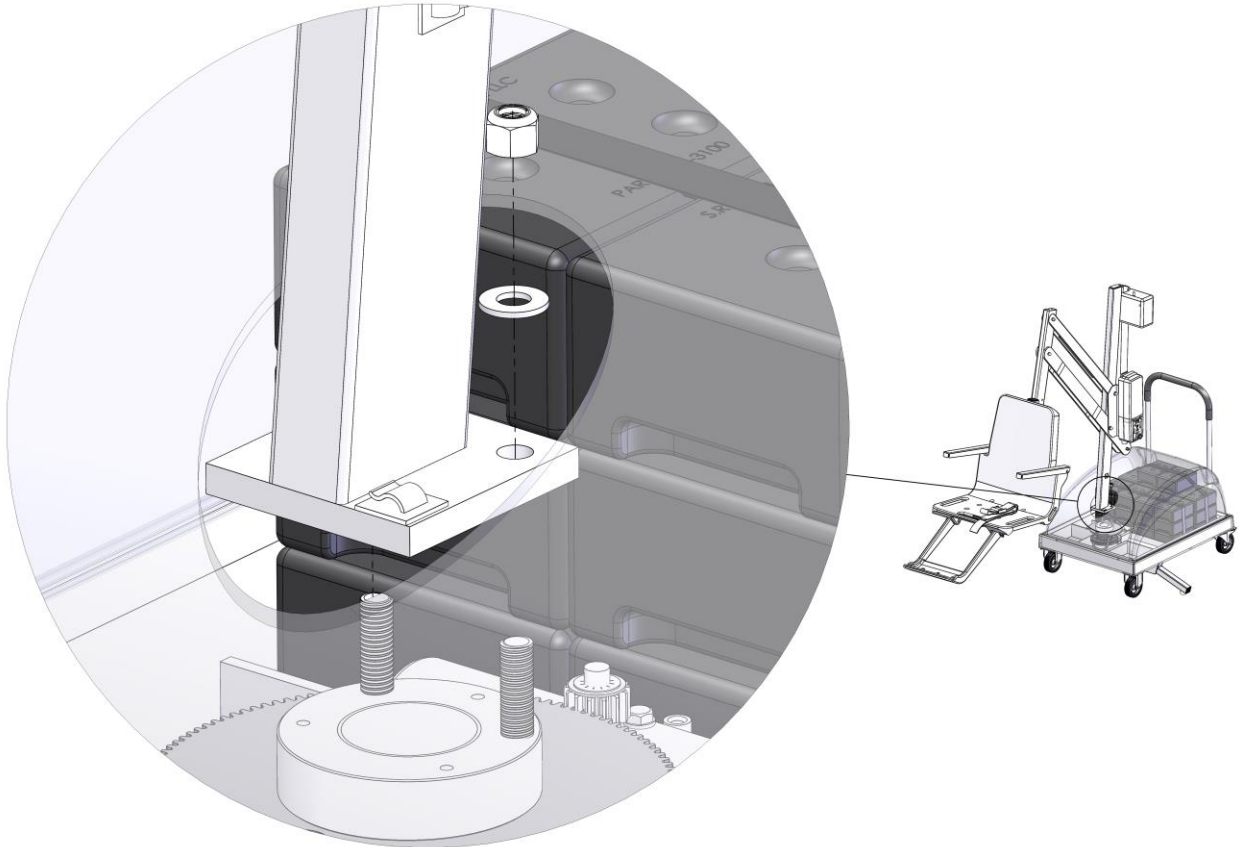

12. Remove plastic from mast assembly. Remove 3/8"(10mm) bolt and nut from actuator arm end. Following the illustration - attach actuator end to end of actuator arm using the same 3/8"(10mm) bolt and nut. Fully tighten bolt and nut using 9/16"(14mm) socket and wrench.

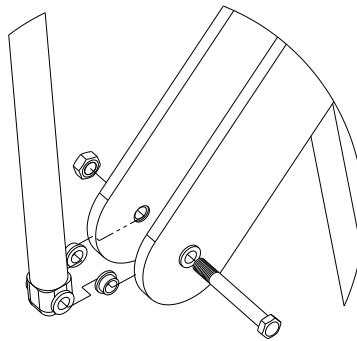

13. Attach battery to Control Box. (Note: To remove battery pull slightly away from mounting plate and lift battery pack off of the Control Box.)

14. Remove the hand control from the accessory carton. Insert plug into large connector on the Control Box aligning the key way of the plug.

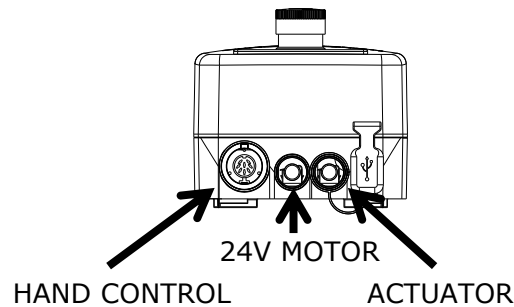

15. Remove twist-tie and uncoil actuator cable (green stripe with the “o” ring) at bottom of mast.

16. Insert actuator cable into connector #2 on the Control Box. Make sure plug is secure.

17. The 24V motor cable will be secured to the mast in **step 19**. For the moment, simply string it through the housing mast hole. Plug the 24v motor cable (red stripe) into connector #1 on the Control Box. Make sure the plug is secure and completely seated. Allow the 24V motor cable to hang freely and untangled from the first pre-installed clip.

18. With the battery connected and the 24V Motor plugged in. Rotate the lift using the right arrow so that the white plastic wire clips attached to the **mast** face forward. Next, unplug the 24V motor cord from the controller.

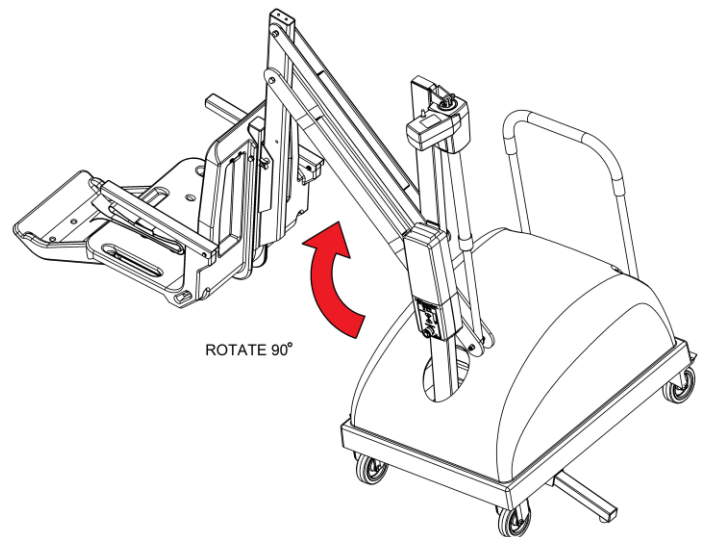

19. To secure the motor cord, follow the steps in the figures below -

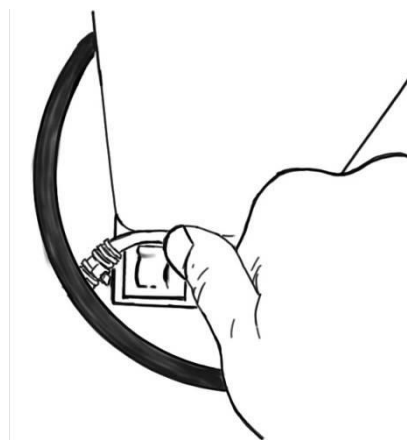

A: Clip the wire into the lower mast clip

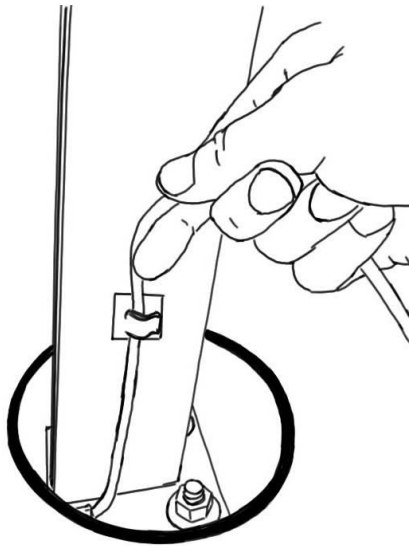

B: Lightly tension the wire and clip it into the higher mast clip.

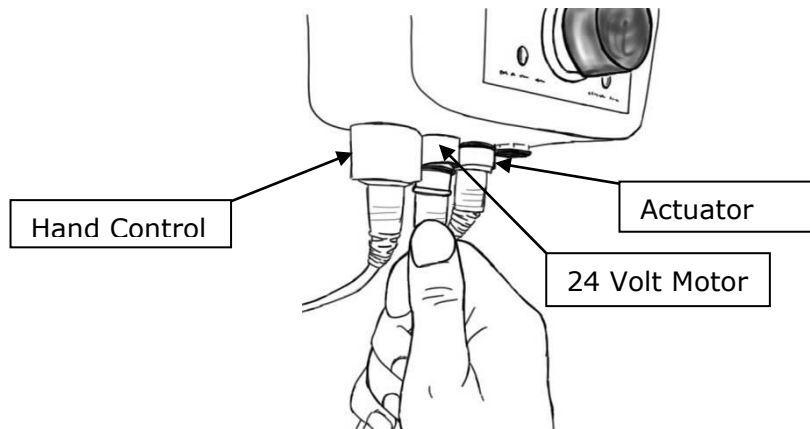

C: Make sure there are no tangles. Then plug the 24V Motor into place.

20. Cover Control Box and battery with Console/Battery Cover to protect from moisture.
21. Check up and down controls for proper operation - both touch pad and hand controls.
22. Check left and right controls for proper operation - both touch pad and hand controls.
23. Check Emergency Stop button for operation/activation of internal sounder.
24. For Controls with the optional Activation Key – Key must be inserted into slot for operation. When Key is removed lift will not operate. (Note – Emergency Stop button and alert will operate without Key inserted into slot)
- 25. Remove the battery and charge it fully before users begin to use the lift.**
26. Fully extend both stabilizer bars and fully lock both rear wheels to prevent movement.

27. Attach seat assembly with bolt and thumbnut in appropriate hole. For storage, seat can be attached facing inward for less space.

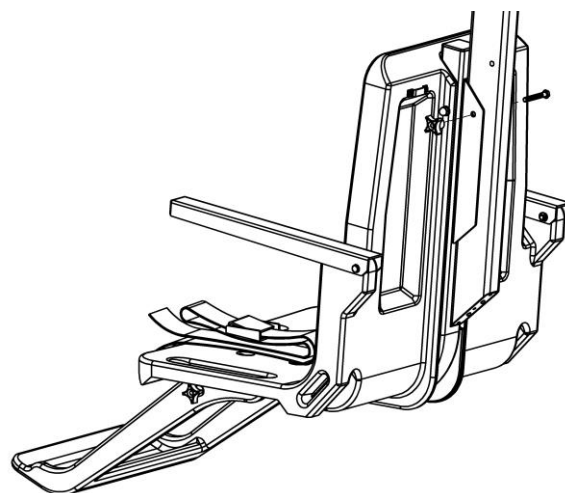

28. Attach foot rest to seat with bolts and thumbnuts.

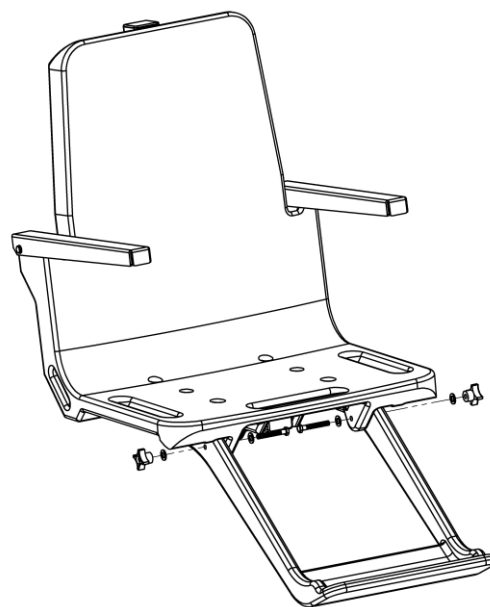

USING THE PAL – Portable Aquatic Lift

Obey all User Instructions listed in the Owner's Manual whenever using lift. Obey all Caution, Warning, Operating Instruction(s) and Labels located on the lift whenever using. It is the responsibility of the lift Owner to ensure that the correct safety procedures have been put in place and a risk assessment carried out. If a User is mentally challenged or has severe physical disabilities these issues must be taken into account to determine the number of persons required to complete the transfer onto the seat and the number of persons required to be in the water, ready to receive the User. If the PAL will be used by a disabled person living on their own, a communication device should be installed in the area of use to call for assistance in the event of an emergency. Only persons healthy enough for water activities should use the PAL. Users should consult with their physician to determine if water activities are appropriate for the User. Keep fingers and hands clear of lift arms during use.

POSITIONING

Four important things to REMEMBER when positioning the PAL for use:

1. Maintain a firm grip on the handle - use care when positioning the PAL. It is heavy (1060 lb/ 481 kg) Do not use the seat as a hand hold to position the PAL – Only use the handle.
2. Position the PAL on level ground not to exceed a slope of 2° and in an area that allows plenty of room for transferring to and from a wheelchair.
3. Fully extend both stabilizing arms.
4. Lock both rear wheels.

WARNING: Failure to fully extend both stabilizing arms and to lock both rear wheels could cause lift movement during transfer and could result in injury. Both stabilizing arms must be fully extended and both rear wheels must be locked whenever lift is used. Do not retract stabilizing arms or unlock rear wheels during transfer as the lift could move and may result in injury. The maximum lift capacity is 300 lb/136 kg. Keep fingers clear of lift arms during use.

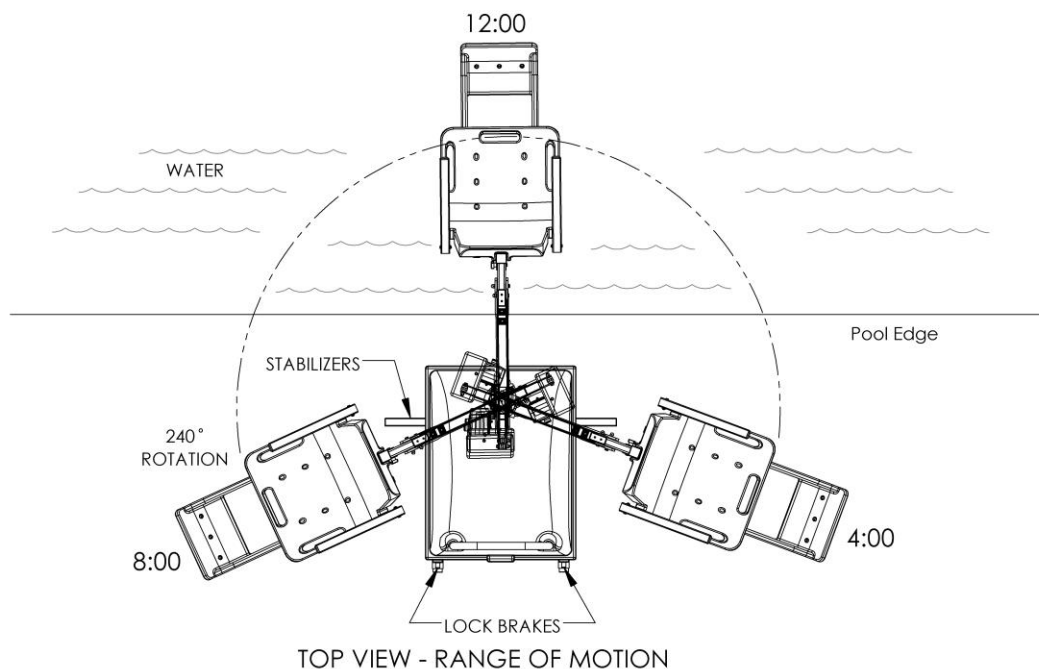

PAL Positioning Diagram

TRANSFERRING

Once the unit is positioned for use with both stabilizing arms fully extended and both rear wheels locked - use the following procedure to transfer to the seat and into the water. Only persons healthy enough for water activities should use the PAL. Users should consult with their physician to determine if water activities are appropriate for the User:

- Keep fingers and hands clear of lift arms during use.
- Rotate seat to either side of lift for best transfer position.
- Raise or lower seat to proper transfer height.
- Transfer onto seat, ensuring user's weight is centered on seat. Armrests can be rotated up if necessary. If user has a wheelchair, keep chair close by for easy retrieval.

- Fasten Seat Belt - thread loose end of belt strap through buckle - pull tight - to close - press latch down on belt material.
- Raise seat to allow enough legroom for rotation.
- Rotate seat to 12:00 position, over water.
- Lower seat into pool. The waterproof hand control can remain connected to seat if swimmer is operating lift.
- Unfasten Seat Belt - grasp latch and lift up, pull loose end from latch.
- When finished, return to seat, ensuring user's weight is centered on seat.
- Raise seat to allow enough legroom for rotation.
- Rotate seat to original transfer position.
- Raise or lower seat to proper transfer height.
- Unfasten Seat Belt.
- Transfer off of seat.

WARNING: The PAL lift is designed to transfer (lift) users from the deck surrounding the swimming pool/spa into the water and back again. It is not designed to transport users from place to place. Serious injury can result if the lift is moved while a user is in the seat.

IN CASE OF HAND CONTROL FAILURE

Lifting failure - In the event of a lifting failure, there are control buttons built into the control box. Press the appropriate up or down/ left or right button located on the front panel of the control box.

If the PAL will be used by a disabled person living on their own, a communication device should be installed in the area of use to call for assistance in the event of an emergency.

STANDARD ACCESSORIES/OPTIONAL ACCESSORIES

The following items are included with all pool lift models:

- Console/Battery Cover - Protects battery and control unit from exposure to moisture.
- Seat Belt Assembly - Nylon water-resistant belt for added security.
- Battery/Charger – 24-volt rechargeable battery.

Optional accessories may be purchased for your PAL - Portable Aquatic Lift through your Authorized Reseller. The following accessories are available:

Total Cover - P/N 920-5000: Made of weather resistant nylon material to keep unit protected from elements when not in use.

Spine Board Attachment - P/N 500-1000: Can be used to convert lift for use with any standard spine board. (Spine Board not included)

PAL Secure-it Kit- P/N 200-1090A: Used to secure lift in place on deck.

MAINTENANCE and CLEANSING

Minimal maintenance will prolong the life of your lift. Keep all electronic components clean and dry. Keep the Console/Battery Cover installed at all times to prevent moisture from collecting on the Control Box and battery. Excessive moisture collection can affect battery and lift performance and could lead to battery failure and/or the lift failing to operate. If the lift is used outdoors, an optional full cover is available and recommended.

Owners of lifts shall be aware of any applicable local, state/provincial or federal/national regulations regarding the inspection and or testing of lifts.

The following schedule must be performed to insure proper operation with the Daily items performed before each use:

Maintenance Performed	Daily	Weekly	Monthly
Check battery level before each use / Charge battery daily	✓		
Wipe Control Box and battery connection with a clean dry rag	✓		
Examine lift for any damage, loose or missing hardware	✓		
Test for normal operation	✓		
Spray gear assembly with a heavy-duty rust inhibitor/lubricant such as LPS 3 - Heavy-Duty Inhibitor		✓	
Make sure all cable connections are properly secured			✓
Inspect lift frame, mast, support arm and seat assembly for rust			✓
Inspect weight stack for rust/treat with touch up paint			✓
Cleansing Performed – after each use			
Rinse seat and seatbelt with fresh water between each use - Cleanse seat and seatbelt with a disinfectant solution of 1:100 dilution of household bleach to fresh water and then rinse with fresh water and dry entire lift daily. In the event of a contamination incident such patient/user excreta - cleanse seat and seatbelt immediately with the disinfectant solution*	✓		
Cleanse all battery connections with a nylon scouring pad			✓
Cleanse all metallic surfaces with a cleaner wax to maintain the finish of the lift			✓

* When using the disinfection solution avoid direct contact with the skin and eyes. In the event of a contamination incident - immerse the seat belt in the disinfection solution for 10 min. and then rinse thoroughly with fresh water.

TROUBLE SHOOTING

Be sure the battery is fully charged before troubleshooting.

Lift does not rotate

Does lift raise or lower?

Yes.

1. Check connection to Control Box. Be sure plug is pushed in all the way.
2. Check hand control connection to Control Box for damaged pins.
3. Check connections on terminal block located on frame for loose wires.
4. Check connection cable for damage.
3. Try operating the lift using the control buttons on the front panel of the controller. If the lift rotates when using the buttons on the control box, the hand control is likely the problem.
5. If the lift does not rotate when using the buttons on the control box, reverse the motor cables as follows: Locate the area on the Control Box where the cables are attached. Swap the actuator cable from connector #2 and the 24v motor cable from connector #1. Activate the up and down buttons on the hand control. If lift rotates, the problem is likely the hand control. If lift does not rotate, the problem is likely the 24v motor.
6. Contact your Authorized Reseller or S.R. Smith for component replacement information.

Does lift raise or lower?

No.

1. Check battery charge level.
2. Check battery connection.
3. Use another fully charged battery. If lift continues to not function, replace the Control Box.

Lift does not Raise or Lower

Does lift rotate?

Yes.

1. Check connection to Control Box. Be sure plug is pushed in all the way.
2. Check hand control connection to Control Box for damaged pins.
3. Check connection cable for damage.
4. Activate the up and down buttons on the front panel of the control box. If lift raises and lowers, the problem is likely the hand control.
5. If lift does not raise and lower when using the buttons on the control box, reverse the motor cables as follows: Locate the area on the Control Box where the cables are attached. Swap the actuator cable from connector #2 and the 24V motor cable from connector #1. Activate the left and right buttons on the hand control. If lift raises and lowers, the problem is likely the hand control. If lift does not raise and lower, the problem is likely the Actuator.
6. Contact your Authorized Reseller or S.R. Smith for component replacement information.

Does lift rotate?

No.

1. Check battery charge level.
2. Check battery connection.
3. Use another fully charged battery. If lift does not function, replace the Control Box.

LONG-TERM STORAGE

When storing the lift for an extended period of time:

- Wash seat with disinfection solution and then rinse with fresh water and dry entire lift
- Spray gear assembly with a heavy duty rust inhibitor and lubricant such as LPS 3 - Heavy-Duty Inhibitor
- Keep the battery on the charger in a dry temperature controlled area
- Cover unit and store in a dry location away from pool chemicals

CUSTOMER CARE

Customers are encouraged to read and obey all of the user instructions listed in this manual whenever using the lift. Comply with all Caution, Warning, Operating Instructions and Labels located on the lift. If the lift will be used by a disabled person independently, a communication device should be available in the area in the event of an emergency. Only persons healthy enough for water activities should use the lift. Users should consult with their physician to determine if water activities are appropriate for their condition. Keep fingers and hands clear of lift arms or pinch points during use.

In the event of a malfunction of the lift or serious incident to a user, contact SR Smith at 1-800-824-4387 or email at customer care@srsmith.com.

Questions/Comments - Contact us at 800.824.4387 or 503-266-2231 or customercare@srsmith.com. For information regarding Authorized Resellers worldwide visit www.srsmith.com

WARRANTY INFORMATION

The S.R. Smith warranty becomes effective on the date of manufacture.

To initiate a warranty replacement, Please follow the process outlined below.

1. **Take photos of the damaged product.**
 - a) The photo must include the entire unit
 - b) Also include one photo or more of the damaged area.
2. **Write down or take a photo of the serial # sticker from the product.**

S.R. Smith provides a serial # for every pool lift we produce. The sticker with the serial number can be found at the bottom of the mast near the base.
3. **Attach the photos and the serial # to a written request for replacement under the S.R. Smith warranty.** Please include the following information:
 - a) Product name and description.
 - b) Date of purchase and/or date of installation.
 - c) Description of damage.
 - d) Shipping address with a contact name and phone number.
4. **Send photos, serial # sticker and your written request by email or mail to customercare@srsmith.com or:**

S.R. Smith, LLC
PO Box 400
1017 SW Berg Pkwy
Canby, OR 97013
Attn: Warranty Specialist

****NOTE:** Missing information will result in a processing delay and possibly denial of your claim.

Should you have any questions regarding this process, please contact S.R. Smith's Warranty specialist at 800.824.4387 or 503.266.2231 or email customercare@srsmith.com

SPECIFICATIONS

PAL/200-0000/EU/K - PAL Hi-Lo/250-0000/EU/K - PAL Spa/275-0000/EU/K

1. Dimensions/Capacity

Overall Height	66"/167.6cm
Base Dimensions	Height 22.5"/55.1cm, length. 37.5"/95.2cm, width 27.5"/69.8cm
Overall Length with Footrest	106"/269.2cm (fully extended)
Overall Length without Footrest	91"/231.1cm (fully extended)
Overall Length in Stored position	61"/154.9cm (fully raised)
Total Weight	1060 lb/481 kg
Power	24V DC
Battery Life (Charged)	30 cycles (approximate)
Lifting Capacity	300 lb/136 kg
Maximum Deck Slope	2 degrees
Seat Width	23"/58.5cm

2. Actuator

Lifting	Screw Type Mechanical Actuator
Max. Thrust	1680 lb/7472N
Voltage	24V DC
Max. Amp	9
Max. Speed	0.59 inch/sec./1.49cm/sec.

3. Motor

Rotation	24V DC 13 RPM
Gearing Ratio	9:1

4. Battery

Power	24V DC, IPX3 Gel Lead Acid
Temperature Range	41 F (5 C) to 104 F (40 C)

5. Range of Motion

Lifting	Variable to configure to each pool. 44" - 58"/112cm – 147cm total travel from highest to lowest point w/ standard actuator.
Seat Depth	18"-20"/46cm – 51cm below water line. Rotation: 240°

6. Noise

Noise level below 50 dB (A), measured according to DS/EN ISO 3746"

7. Materials and Finish

Frame	Powder Coated Stainless Steel
Handle	Powder Coated Aluminum
Housing	Vacuum Formed ABS Plastic
Casters	
Front	Ball Bearing, Stainless Steel, 5"/12.7cm Fixed, Polyurethane Tread
Rear	Ball Bearing, Stainless Steel, 5"/12.7cm Total Lock Swivel, Polyurethane Tread
Arms	Powder Coated Aluminum
Mast	Powder Coated, Stainless Steel
Seat Assembly	Seat: Roto-Molded Plastic Frame: Powder Coated Stainless Steel

PART LIST (PAL)

Item #	Part #	Description
1	100-5000A	LA34 Actuator
2	1001499	4 Button Control
3	1001555	4 Button Control w/Activation Key
4	1001495	Battery Pack
5	1001530	Battery Charger (not shown)
6	910-1000	Console Cover (optional accessory, not shown)
7	120-1100	24v Motor
8	800-5065	Small Gear
9	130-1000	Hub Assembly
10	120-1000	Motor Mount Assembly
11	150-1100A	Mast Assembly
12	150-1200A	Actuator Arm
13	150-1300A	Support Arm
14	150-1400	Seat Arm
15	160-8000A	Seat Assembly
16	160-2300A	Foot Rest
17	200-1000	PAL Main Frame Assembly
18	200-2000	Rigid Caster
19	200-3000	Swivel Caster
20	110-3100	Cast Iron Weight Plates
21	200-5000	PAL Housing Assembly
22	200-4100	Stabilizer Assembly
23	200-1090A	PAL Secure-it Kit (not shown)
24	900-1000	Seat Belt Assembly
25	900-6000	Stability Strap (Optional Accessory, Not Shown)
26	970-5000	Seat Cover (Optional Accessory, Not Shown)

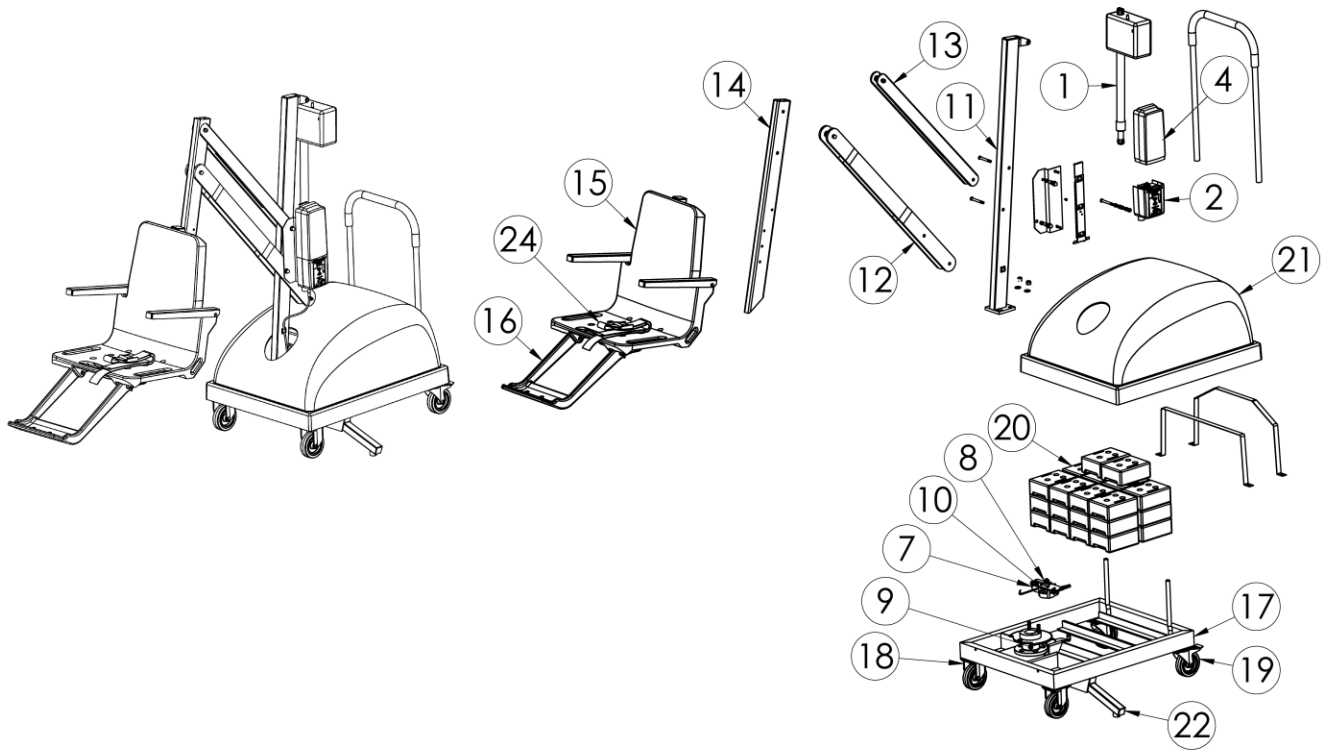

PART LIST (PAL Hi/Lo and SPA)

Item #	Part #	Description
1	100-5000A	LA34 Actuator
2	1001499	4 Button Control
3	1001555	4 Button Control w/Activation Key
4	1001495	Battery Pack
5	1001530	Battery Charger (not shown)
6	910-1000	Console Cover (optional accessory, not shown)
7	120-1100	24v Motor
8	800-5065	Small Gear
9	130-1000	Hub Assembly
10	120-1000	Motor Mount Assembly
11	160-2300A	Foot Rest
12	200-1000	PAL Main Frame Assembly
13	200-2000	Rigid Caster
14	200-3000	Swivel Caster
15	110-3100	Cast Iron Weight Plates
16	200-5000	PAL Housing Assembly
17	200-4100	Stabilizer Assembly
18	150-2100A	Hi/Lo Mast Assembly
19	160-9000A	Hi/Lo Seat Assembly
20	150-2200A	Hi/Lo Actuator Arm
21	150-2300A	Hi/Lo Tension Arm
22	150-2400A	Hi/Lo Seat Arm
23	200-1090A	PAL Secure-it Kit (not shown)
24	900-1000	Seat Belt Assembly
25	160-8000A*	Seat Assembly
26	900-6000	Stability Strap (Optional Accessory, Not Shown)
27	970-5000	Seat Cover (Optional Accessory, Not Shown)

*For Spa model only

