



**DAVEY**  
**ProMatic™**  
**Salt Water Chlorinator**  
**Patent Protected**



**Installation &  
Operating Instructions**



Please pass these instructions on to the operator of this equipment.

# DAVEY ProMatic™

Congratulations. You are now the proud owner of a renowned new Davey ProMatic™ smart “All-in-One” salt water chlorinator. Please read all the information in this manual carefully before installing and operating your new chlorinator.

## Table of Contents

---

|  |    |
|--|----|
| Packing List .....                                 | 2  |
| Important Information .....                        | 3  |
| Important Safety Instructions.....                 | 4  |
| Technical Specifications .....                     | 4  |
| Installation Instructions .....                    | 5  |
| Locating & Mounting.....                           | 6  |
| Connecting the Power .....                         | 7  |
| Connecting Peripherals & Auxiliary Equipment ..... | 8  |
| Replacing an Existing Power Source & Cell.....     | 10 |
| Pre-Start Up Procedure .....                       | 11 |
| Features of Your Chlorinator.....                  | 11 |
| Cell Production .....                              | 12 |
| Operating your Chlorinator .....                   | 13 |
| Functionality of your Chlorinator.....             | 14 |
| Day to Day Operation .....                         | 19 |
| Chlorine Production.....                           | 21 |
| Troubleshooting.....                               | 23 |
| General Information.....                           | 25 |
| Mounting Template .....                            | 26 |
| Guarantee, Terms and Conditions.....               | 28 |

## Packing List

---

Included with your ProMatic chlorinator are the following items, please check the contents of the box carefully prior to installation:

- ProMatic unit
- 2 x barrel unions (with o-rings) suitable for 40/50mm (1.5/2”) pipe
- Mounting kit (includes bracket and screws)
- Installation and Operating Instruction manual



**Note: The Chlorinator is not intended for use by young children or infirm persons without supervision. Please ensure that young children are supervised to ensure that they do not play with the Chlorinator.**

# IMPORTANT INFORMATION ABOUT YOUR CHLORINATOR

## FACTORS THAT WILL IMPROVE THE PERFORMANCE AND LIFE OF YOUR SALT WATER CHLORINATOR

### PLEASE READ THIS BEFORE OPERATING YOUR CHLORINATOR

**POOL BUILDERS:** Please cover this information with your customer during the new pool “Hand over Session”

Salt water chlorinators are a valuable part of your pool equipment and must be cared for to achieve best performance and life span.

There are THREE main rules that must be observed to maintain cell life in your chlorinator. Please ensure you do the following.

### 1. MAINTAIN THE SALT LEVEL

- Ensure that the chlorinator is running in water with a recommended level greater than 4000 ppm of NaCl (pool salt) to ensure optimum sanitiser output and cell life. Your chlorinator can run in sea water if required
- Operating this device at low salt levels will reduce the chlorine output and shorten the life of the cell. Damage caused by running the cell at low salt levels is NOT covered by warranty.
- The chlorinator will display a warning message for low salt levels which will cause the chlorine output to drop. Once enough salt is added to the pool this warning message will vanish

### 2. MONITOR THE CHLORINATOR

- Davey recommends regular monitoring of your chlorinator for optimum performance
- For optimum performance, regularly check your water chemistry to ensure it is balanced
- Periodically check (weekly) the display screen to see if there are any problems with your chlorinator and its chlorine production
- In the event of any error messages appearing please refer to the Troubleshooting section

### 3. BALANCE THE POOL WATER CHEMISTRY

- It is recommended that salt levels should be maintained at greater than 4000 ppm for optimum performance and lifespan
- Optimum Calcium hardness levels should be within 200 to 275 ppm (for concrete & tiled pools) and 100 to 225 ppm (for fibreglass and vinyl liner pools) to prevent damage to equipment
- pH levels must be kept between 7.2 and 7.6 to prevent damage to equipment and pool surfaces as well as to achieve optimum sanitisation
- Total alkalinity and stabiliser levels must also be kept within the recommended range (Alkalinity 80 to 120ppm) and (Stabiliser 30 to 50ppm)
- Please refer to the Recommended Pool Chemistry chart in the Day to Day Operation section for details on how to balance your pool water

## IMPORTANT SAFETY INSTRUCTIONS

When installing and using this electrical equipment, basic safety precautions should always be followed.

1. Read and follow all instructions in this document.
2. To reduce the risk of injury, only permit people who have read these instructions to use this product.
3. To prevent electric shock, connect only to a weatherproof general purpose electrical outlet. Earth must be connected and the electrical outlet must be protected by a residual-current device (RCD) or a ground fault circuit-interrupter (GFCI). Contact a qualified electrician if you cannot verify that the receptacle is protected by a RCD or GFCI.
4. Do not bury or coil the supply cord.
5. The terminal cover must be screwed down securely with supplied o-ring and insert in place. Disconnect mains power before removing this cover to attach peripheral devices.
6. To reduce the risk of electric shock, do not use an extension cord to connect the chlorinator to power, instead provide a properly located outlet.
7. This unit is to be installed in accordance with these installation instructions and any local Electrical Codes and the requirements of the authority having jurisdiction.
8. The chlorinator must be positioned downstream of all pool equipment including pumps, heaters, filters, cleaners and so on. Note: If an Ozone generator is installed this **MUST** be installed after the cell.
9. Keep these instructions in a safe place for future reference.

## TECHNICAL SPECIFICATIONS

| ProMatic 24                                     |  |
|---|--|
| <b>Input Voltage (RMS)</b>                      | 120/240V   |
| <b>Input Current Draw</b>                       | 2/1A   |
| <b>Frequency</b>                                | 50/60Hz  |
| <b>Phase</b>                                    | Single   |
| <b>Maximum Cell Output (DC)</b>                 | 9V/24A   |
| <b>Maximum Pump Current Draw (AUS/NZ)</b>       | 9A   |
| <b>IP Rating</b>                                | 45   |
| <b>Maximum Chlorine Output</b>                  | ProMatic model (DAMC24G) 24g/h (0.0529 lbs/h)                      |
| <b>Recommended Salt Level</b>                   | Minimum 4000 ppm - Maximum 6000 ppm                                |
| <b>Minimum Pool Size</b>                        | 5kL (1.3kgal US)   |
| <b>Maximum Pool Size</b>                        |  |
| <b>Cold Climate ≤ 20°C (68°F)</b>               | 125kL (33.0kgal US)  |
| <b>Temperate Climate 25°C (77°F)</b>            | 75kL (19.8kgal US)   |
| <b>Hot &amp; Tropical Climate ≥ 30°C (86°F)</b> | 55kL (14.5kgal US)   |
|   | Climate indicates <b>WATER</b> temperatures during swimming season |
| <b>Water Temperature Range</b>                  | >0 to 40°C (32 - 104°F)  |
| <b>Recommended Flow Rate</b>                    | Minimum 80 LPM (21.5gal/m) – Maximum 400 LPM (106gal/m)            |
| <b>Height</b>                                   | 521mm (20.5")  |
| <b>Width</b>                                    | 217mm (8.5")   |
| <b>Depth</b>                                    | 217mm (8.5")   |
| <b>Weight</b>                                   | 6.6kg (14.6lbs)  |

# INSTALLATION INSTRUCTIONS

Please note that the installation area should be well ventilated and free of substances that cause corrosion such as fumes from concentrated chemical chlorine, acid and so forth. Failure to ensure a well ventilated area may result in damage to the electronics, voiding warranty.

The chlorinator can be mounted in two orientations as shown below, with flow in either direction as indicated by the arrows. Flow rates through the chlorinator should be kept within 80 to 400 LPM (21.5 to 106gal/m).

The chlorinator comes with 2 x 50mm (2") barrel unions and a mounting bracket suitable for all orientations. If using the mounting bracket, first mount the bracket to back of the cell housing with the screws provided. A template provided, on page 26, in this manual can be used for location of drill entry points.

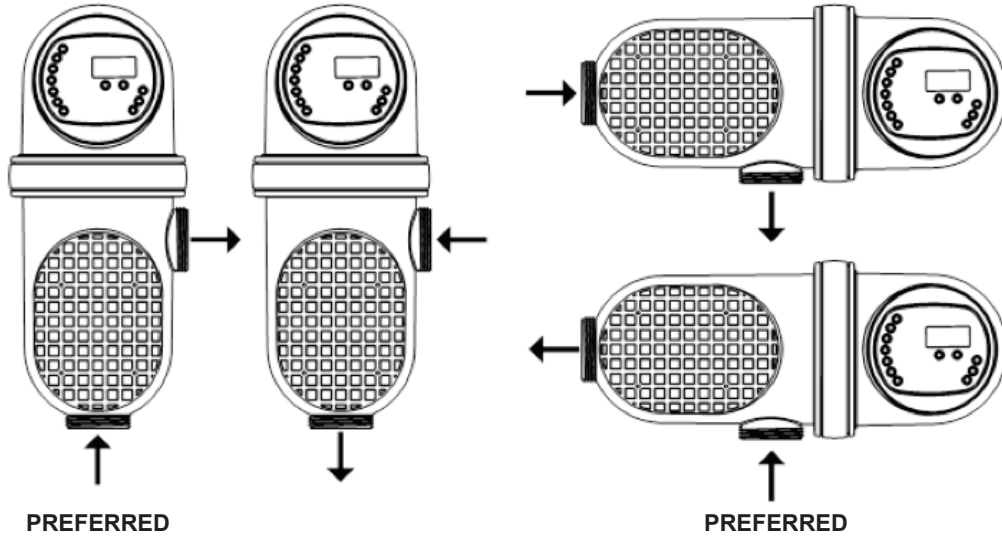

The interface display screen can be rotated by no more than 90°, by hand, to suit the installation orientation.

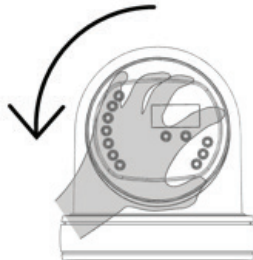

The chlorinator must not be installed in any other orientation or at any angle other than horizontal or vertical. Such an installation will void your warranty.



Variable speed pool pumps, pipe restrictions and undersized or clogged filters can cause very low flow rates through the chlorinator. Excessive air accumulating in the cell may cause the unit to cease chlorine production in order to prevent damage to the equipment. If this occurs, the pump, filter or pipe work will have to be adjusted, cleaned or changed before normal operation can resume.



**Note: In certain installations, the flow rate may be insufficient to fill the cell housing completely with water. In these cases the flow must be increased to ensure that the housing is completely full.**

## LOCATION AND MOUNTING

Select a convenient location to mount the chlorinator. The display screen can be difficult to read in direct sunlight, so a shaded area is recommended. The chlorinator must be kept away from chemical storage areas, including acid and direct heat sources.



**WARNING:**  
The chlorinator contains electronic components which may become damaged if the unit is dropped.



**Note:** The chlorinator must be positioned on the return to pool line after all accessories such as the pump, heater and filter, but before the pipe work divides if there is more than one return to the pool. Ozone generators must be installed after the discharge side of the chlorinator. (Failure to do this may cause damage to the cell and void warranty)

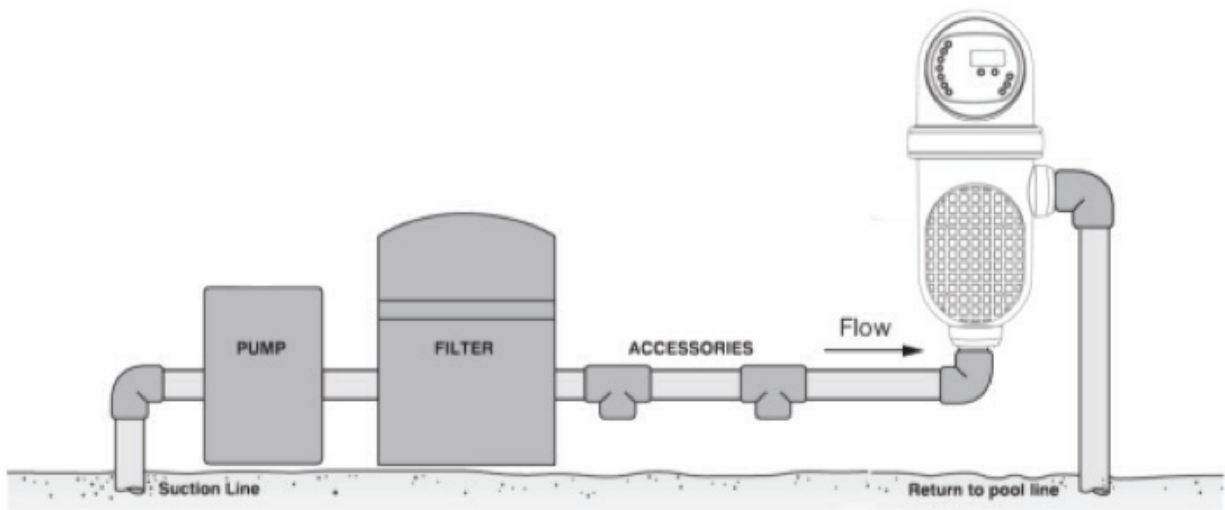

This diagram is intended to conform to the safe operation of saline chlorinators. Any deviation is at the installer's risk and may void warranty.

**Installation must be done in accordance with any local regulations.**

The chlorinator is designed only to run at the flow rates specified. In some instances flow may be too high and so a bypass valve will need to be installed to reduce the flow through the cell as below.

To maximise pump efficiency, all plumbing should be completed using 40 or 50mm (1.5 or 2") PVC pressure pipe. The installer must ensure the chlorinator is provided with adequate support, especially where interconnecting pipe work is unsupported. The dry weight of the unit is 6.6kg (14.6lbs).

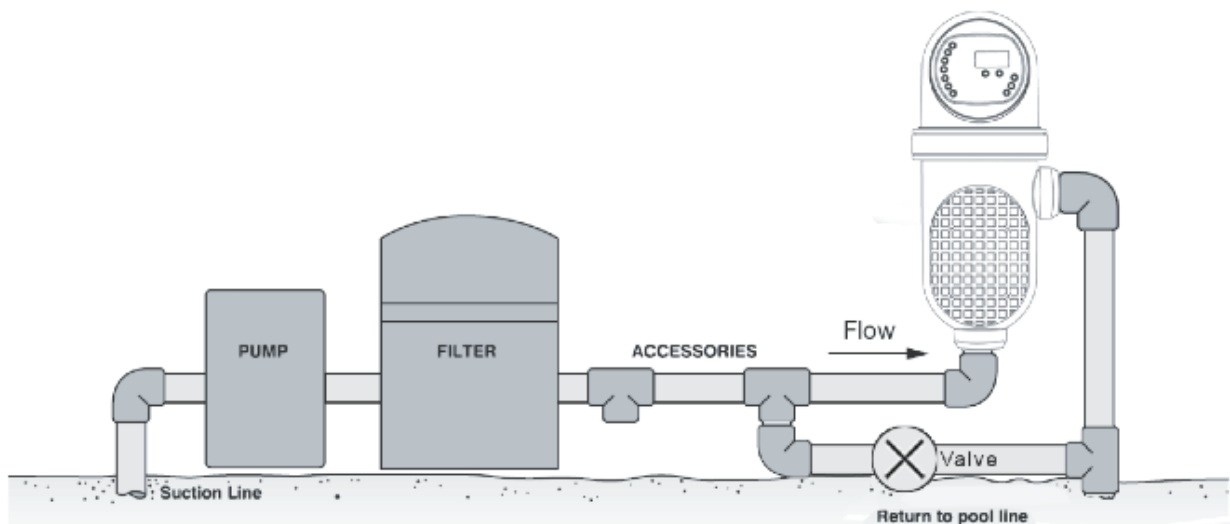

## CONNECTING POWER



Power connections and wiring must be carried out by an authorised electrician.

Plug the chlorinator power cord into a weatherproof general purpose electrical outlet. To ensure your safety, the electrical outlet must include a working earth and must be protected by a residual-current device (RCD) or ground fault circuit-interrupter (GFCI). Installation by a qualified person will allow you to verify that the unit is earthed and protected by a working RCD or GFCI.

In the Australian and New Zealand models, the plug end of the supply cord is fitted with a power socket for connection of a pool filtration pump only. The connected pump will then run automatically according to the operating times set on the chlorinator. Its maximum current must not exceed 9A, 2000W (refer to the pump's technical nameplate to confirm).

Outside of these regions the pool pump must be connected to an external timer or controller, ensuring that the pump is always on during chlorinator operation. In regions where the chlorinator is to be hard wired, a qualified person must complete the installation.



Do not use a double adaptor to connect more than one pump - it can overload the system and could void your warranty.

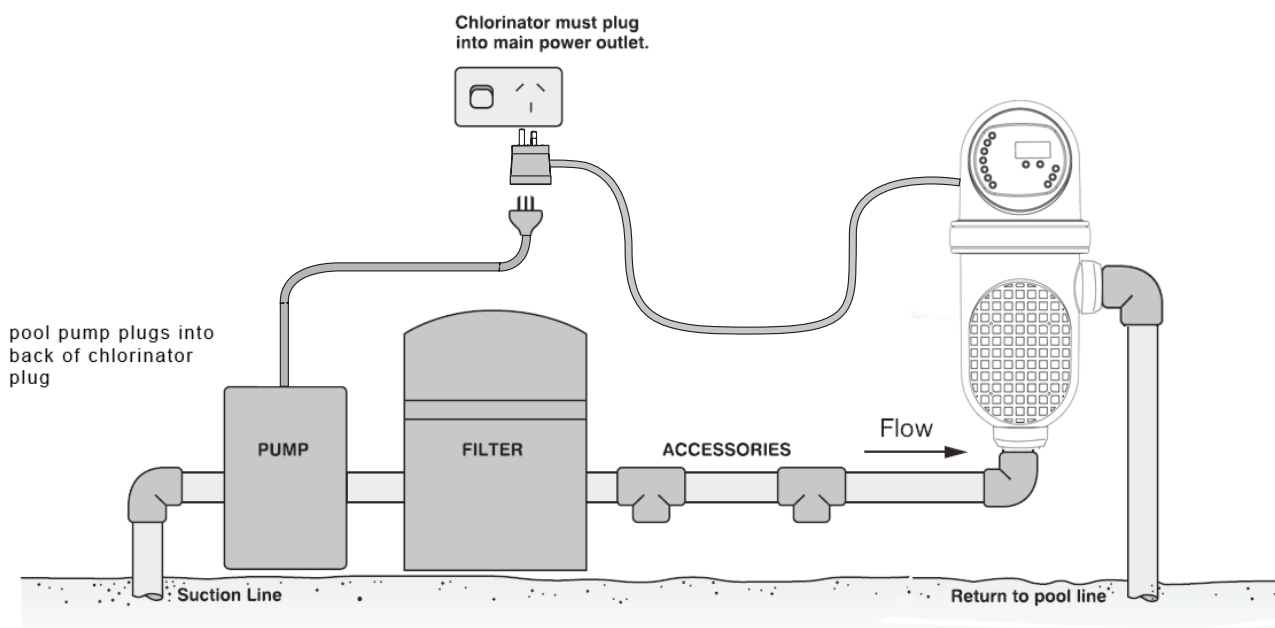

When deciding on the position of the chlorinator, be sure to consider the cord length (4m for the Australian and New Zealand models, 2m (6.5ft) for international models).



**IMPORTANT:**  
If the supply cord is damaged, it must be replaced by an authorised Davey service agent.

## CONNECTING PERIPHERALS



Power connections and wiring must be carried out by an authorised electrician.

A panel on the back of the electronics enclosure provides access to a low voltage (SELV) terminal block allowing for connection of a pool cover micro switch and demand response signals.

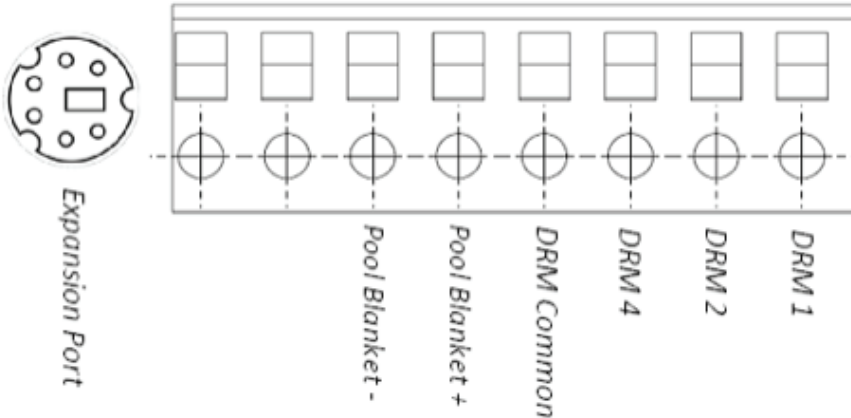

### AUTOMATIC COVER MODE

Automatic Cover Mode is available by connecting a pool cover micro switch (normally open type) across the pool blanket terminals during installation. The micro switch may be up to 10m (32') away from the chlorinator. Cover Mode automatically reduces cell production to 20% when the micro switch is closed (cell production cannot be manually changed whilst in Cover Mode). The LCD display screen will show Cover on Auto when Cover Mode is active.



### DEMAND RESPONSE CONTROL

Your chlorinator is designed to comply with Australian/New Zealand Standard AS/NZS 4755 3.2, which concerns the operation of pool pump controllers for commands transmitted via your electricity provider. During installation, by wiring your smart meter or DRED to the corresponding DRM terminals on the low voltage (SELV) terminal block, the chlorinator can read demand response control signals from the mains electricity supplier and respond appropriately.

When a Mode 1 event occurs the chlorinator will enter the demand response mode turning the cell and pump off. This will help to reduce your power bills during periods of peak demand. The interface will display a message and the active mode LED will flash indicating that it has entered this mode.



To enable demand response control, connect the DRM 1 and DRM Common terminals to your demand response enabling device (DRED).



## CONNECTING PERIPHERALS (CONT)

You can manually override the demand response mode (once during each demand response event) by pressing the up and down buttons simultaneously which will return the chlorinator to normal operation for a period of up to one hour. If the demand response event is still in progress after the override period terminates, the chlorinator will again enter the demand response mode.



**Note: Your chlorinator complies with AS/NZS 4755 3.2 and will respond to DRM 1 type commands only.**

During installation, when connecting any external devices to the chlorinator mains power must be disconnected. Wires sized AWG 26 gauge – 21 gauge (0.1 - 0.4mm<sup>2</sup>) can be used. Wires are routed through the panel as shown below.

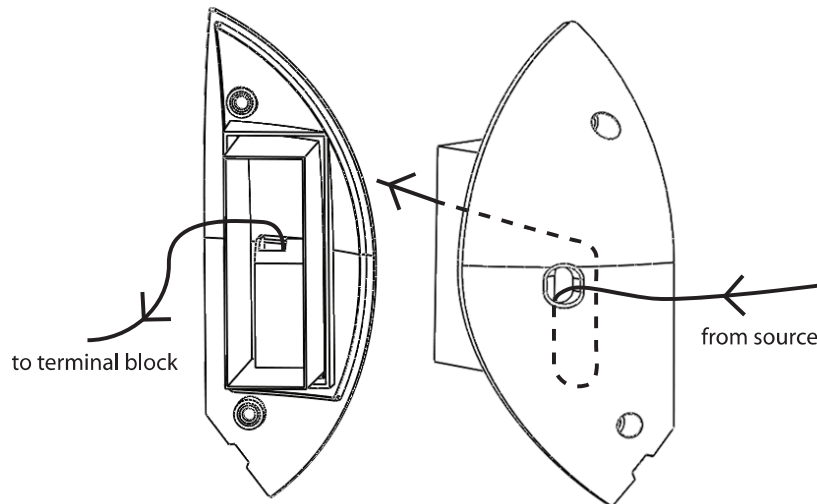

A foam seal is provided to allow wires entry and prevent water ingress. First, remove the seal from the cover panel. Then, put the wires in a row and route them through the slit. Finally, put the seal back into the cover panel making sure there are no gaps around the edges or between the wires.

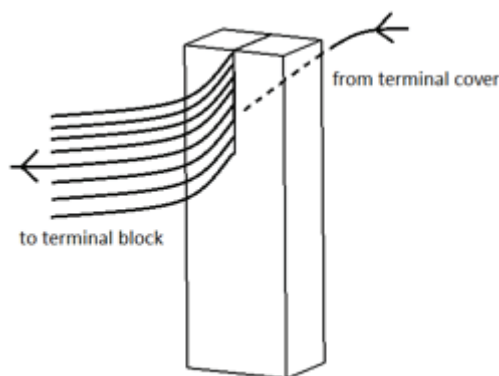

Once external wires have been connected the cover panel must be screwed back into place before restoring power.

## REPLACING AN EXISTING POWER SOURCE AND CELL

When replacing an existing Davey ESC or ESR Power Source and cell, the vertical orientation shown below will help to minimise any pipe work modifications needed.

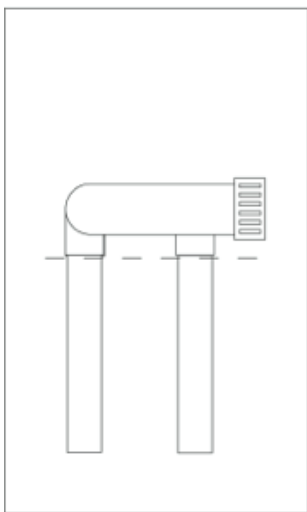
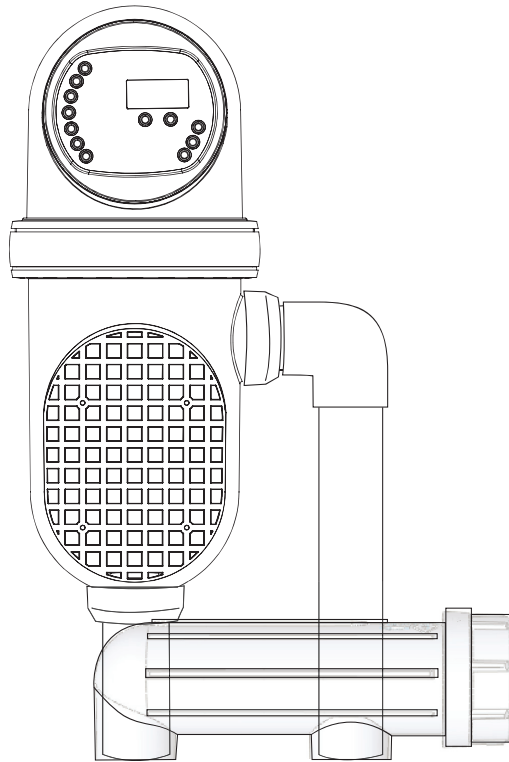

**Step 1**

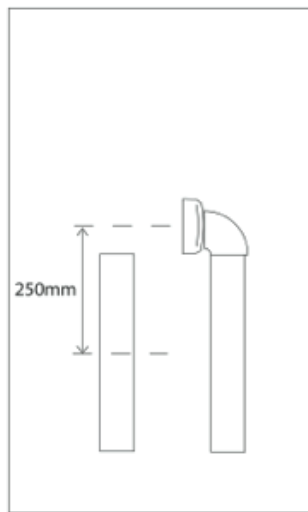

**Step 2**

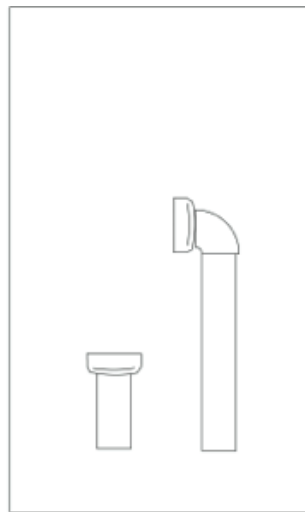

**Step 3**

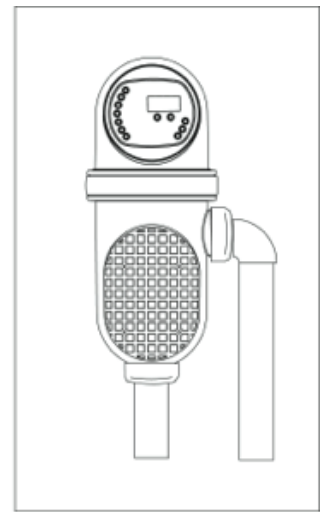

**Step 4**

**Step 1.** Simply cut the existing cell off as shown.

**Step 2.** Glue a 40mm nut & tail (Davey part number 48775B) into a 90° right angled 50mm elbow (this is to ensure that the elbow does not protrude past the width of the original cell), then glue this straight onto the side pipe as shown. Measure down 250mm from the centre of the 90° elbow (centre of the pipe hole) and cut the vertical pipe as shown.

**Step 3.** Glue a 50mm (Davey part number 48722B) nut and tail onto the vertical section of pipe making sure that the Chlorinator will fit between the pipes.

**Step 4.** Mount the chlorinator as shown and secure by tightening the barrel unions.

## PRE-START UP PROCEDURE

Before running your chlorinator for the first time, ensure that the following items have been met.

### 1. Recommended Salt level should be between 4000 ppm and 6000 ppm

Load salt into the pool at a minimum of 40kg (88lbs) per 10,000 litres (2642gal) (that is, 4000 ppm). Allow 24 hours for the salt to dissolve. If a manual vacuum system is connected slowly vacuum until salt dispersal is complete. Place the vacuum head into the deepest end of pool and allow the vacuum to continue for a further two or three hours. Salt should then be completely mixed. Never add salt directly into a skimmer box. Salt is available from your pool shop professional.

### 2. Chlorine level equal to 3 ppm

For a new pool installation that has not been chlorinated, add sufficient Chlorine (liquid or granular) to achieve a reading of 3 ppm (verified with a suitable test kit). Alternatively after chlorinator setup is complete run the chlorinator in Boost mode until a reading of 3 ppm is reached.

### 3. Stabiliser level between 30 and 50 ppm (for outdoor pools only)

It is essential that pool stabiliser be added and maintained to a level of 30 – 50 ppm at all times. Do not exceed 100 ppm.

Refer to the *Day to Day Operation* section for further information.

## FEATURES OF YOUR CHLORINATOR

### PUMP CONTROL

Your chlorinator is intended to be used in conjunction with domestic and light commercial pool pumps. This includes use with non-Davey pumps.

For Australian and New Zealand regions the chlorinator provides power to the pool pump to run during filtration cycles. The pool pump is plugged into the back of the chlorinator's piggyback plug, the power socket is dedicated to the pool filtration pump only and cannot be used to drive multiple pumps. The pump's maximum amperage must not exceed 9A, 2000W.

Outside of these regions control of the pool filter pump must be done with an external timer or controller, ensuring that the pool filter pump is always on when the chlorinator is in operation.

### MANUAL & TIMER OPERATION

Manual mode allows you to manually start and stop chlorine production. The chlorinator has two programmable timers to specify on and off times for daily automatic operation of the cell when running in timer mode.

### FLOW SENSING

A built-in sensor will shut down operation of the filtration pump and chlorine production if it detects that water flow through the cell is too low for safe operation, or the cell is dry. If no flow is detected, the chlorinator will shut off the cell immediately in order to prevent gas build up and continue to run the pump for up to twenty minutes to allow any air to purge and flow to resume. If flow is not detected within this time the chlorinator will shut off the pump. In which case, the flow error can be cleared and the chlorinator restarted by pressing a mode select button.

### WATER TEMPERATURE SENSING

Standards in most countries require that pool and spa water temperatures do not exceed 40°C (104°F) for the health and safety of swimmers; this is also the operational limit for many pool pumps. To guarantee the reliability and safety of your pool equipment, the chlorinator will turn off the cell if it detects water temperatures above this limit. However the pump will continue to run.

### OPTIMISED CELL OUTPUT

The maximum output for the unit is 24 grams (0.0529 lbs) of chlorine per hour in pool water with a salt level of 4000 ppm or more. The chlorine output will be optimised to suit the pool size entered during the initial setup. It is important to enter your pool size correctly, so you may need to ask your pool dealer for advice on how to calculate your pool volume, which can be entered in litres or gallons (US).

Chlorine demand is strongly affected by water temperature. The chlorinator will monitor the water temperature and automatically adjust to give an appropriate output. Please read the Chlorine Production section for important details about getting your chlorinator settings correct.

## CELL PRODUCTION

You can control the production of chlorine in two ways.

- 1) By increasing the daily run time.
- 2) By adjusting the cell production (operation during the daily run time) from 0 to 100%.

Daily run time should be adjusted to ensure the volume of your pool water is circulated through your filter at least once every 8 hours in high bather load months (summer).

Cell production controls the amount of time the cell operates during the daily run time. For example, during a five hour filtration period, if you set cell production to 80% the chlorinator cell will operate for a total of four hours.

Please refer to the Chlorine Production section for detailed instructions on getting your sanitiser settings correct.

## STANDBY

A standby message is displayed during manual start up or at the commencement of a timer period. Standby lasts for approximately three and a half minutes, allowing the pump to prime and the chlorinator to perform a cleaning cycle and a series of checks and measurements.

## AUTOMATIC CLEANING

Your chlorinator automatically removes calcium scale from the cell, even in hard water, eliminating or dramatically reducing the need for periodic maintenance. Calcium removal occurs once for every half hour of chlorination.



**Note: A combination of factors including high water temperature, very hard water, low flow rates and high pH may cause calcification. Where this situation cannot be corrected, additional manual cleaning of the cell may be required. Refer to the Day to Day Operation section for more details.**

## TDS MEASUREMENT

The chlorinator provides a guide to your pool salt levels and displays a LO, OK or HI Salt Level reading. This allows you to optimise chlorine production and maximise your cell life by ensuring your salt levels are within the recommended 4000 ppm to 6000ppm.



Whilst this is a guide only, Davey always recommends you take a sample of your pool water to your local Davey dealer or pool shop, for testing.

The salt level readings are only applicable to pools using sodium chloride (NaCl, Salt).

After adding salt, or if the filtration pump has not run for an extended period, it may take a day of normal operation for the salt reading to stabilise.

It is also important to note that in hard water areas your TDS readings may vary. If you have high TDS readings this generally indicates hard water, which can cause scale buildup on your cell reducing its performance. Typically, in these applications, total dissolved solids are tested regularly and cells are required to be cleaned more frequently in order to prevent any adverse effects. See the Day to Day Operation section (Manually Cleaning your cell on page 24) for instructions on how to clean your cell.

# OPERATING YOUR CHLORINATOR

## THE CONTROL DISPLAY

The function buttons on the chlorinator display screen give you quick and easy access to the adjustable features that allow you to maintain your pool.



The following will take you through each one of the chlorinator's functions and settings, one at a time.

### RUNNING THE CHLORINATOR FOR THE FIRST TIME

When running the chlorinator for the first time only, you'll be prompted to select the interface language, pool size and current time. The following screens will be presented to you in sequence.

First set the interface language.



Then set your pool size.



Finally set the clock.



The chlorinator then returns to the default display.

# FUNCTIONALITY OF YOUR CHLORINATOR

## CELL OFF MODE

Pressing the Cell Off button turns the filter pump and chlorinator cell off. In this mode no chlorine will be produced.

## TIMER MODE

Pressing the Timer button starts timer operation. Timer mode automatically runs the chlorinator cell and pump during the set timer periods. Make sure you have set up the timers before running in this mode (see Setting the Timers below).

## MANUAL MODE

Pressing the Manual / Boost Mode button once will run the chlorinator cell and pump independently of the timer settings. When left in this mode, the chlorinator will run continuously.

## BOOST MODE

You can choose the Boost Mode by pressing the Manual / Boost Mode button twice. This will run the unit at 100% of the pool size maximum output for a 24 hour period before reverting back to either Timer or Manual mode operation. When in Boost Mode the LCD display screen will say Boost Mode On. The Manual Mode LED lamp will flash during the 24 hour Boost period.



**Note:** You can go back to either Manual or Timer mode at anytime by pressing the desired function button.

## CELL PRODUCTION

Pressing the Cell Production button allows you to control the rate of chlorine production over the daily run time (filtration period). Pressing the up and down buttons will change the output in 1% increments. Holding either button down will change the output in 10% increments. The lowest allowed output is 5%, although 0% can be selected to run the pump (with the cell off) if extended filtering times are required.

Refer to the *Chlorine Production* section for important information on how to maintain your chlorine levels.



## FUNCTIONALITY OF YOUR CHLORINATOR (CONT)

### POOL SIZE / LANGUAGE

Pressing the Pool Size/Language button once allows you to set the pool size. Pool size is adjusted via the up & down buttons. Pressing both the up & down buttons simultaneously will change the display between kL (thousands of litres) and kgal (thousands of US gallons). Pressing the up and down buttons will change the pool size in increments of 1kL (0.26kgal). Pressing and holding either button down will change the pool size in 10kL increments. The minimum pool size is 5kL (1.3kgal) and the maximum pool size is 125kL (33.0kgal). If you are using the chlorinator on an even larger pool, please set the pool size to the maximum and refer to the instructions in the Chlorine Production section.

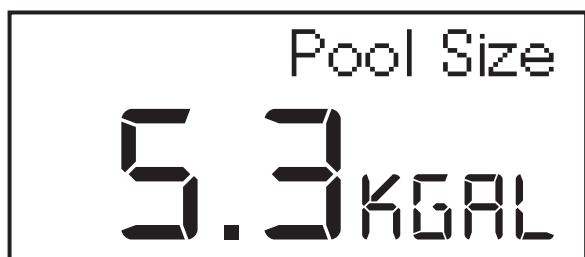

### LANGUAGE

You can choose the message display language by pressing the Pool Size/Language button twice. Then select your desired language by cycling through the languages displayed using the up and down buttons. The available languages are English, Français, Español, Slovenský, Deutsche, Italiano, Português & Nederlands.



## FUNCTIONALITY OF YOUR CHLORINATOR (CONT)

### BACKWASH FILTER

The backwash filter function is used when you need to backwash, rinse and clean your media filter to waste. It runs the filter pump during back wash mode and reduces the chlorine output to 0%. The filter pump will run for a maximum of 2 minutes on each cycle.

**Step 1.** Press the Backwash Filter button once, this will turn the chlorinator and filter pump off.

**Step 2.** The LCD display screen will show Change Valve. Turn your media filter valve to the Backwash position.

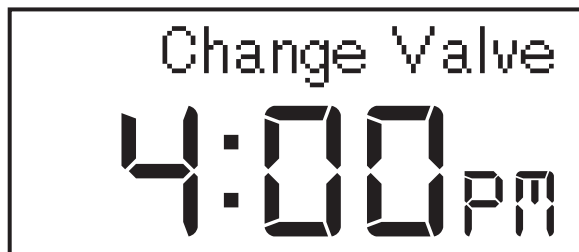

**Step 3.** Press the Backwash button again this will start the filter pump. The LCD display will show **Pump Running**. After 2 minutes the filter pump will switch off. The LCD display screen will show **Change Valve**. (If a further 2 minute backwash cycle time is needed, repeat Step 3 and press the Backwash Filter button again).

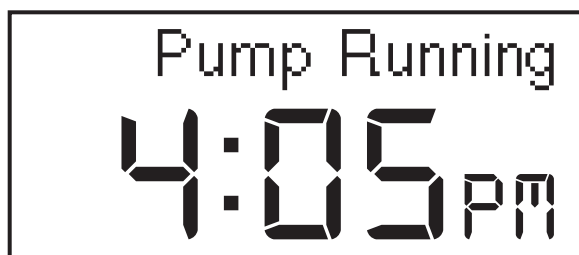

**Step 4.** Once the filter pump is off, adjust the media filter valve to the Rinse position and press the Backwash Filter button again. The LCD display screen will show Pump Running. After 2 minutes the filter pump will switch off. The LCD display screen will show Change Valve. (If a further 2 minute rinse cycle time is needed, repeat Step 4 and press the Backwash Filter button again).

**Step 5.** Once the pump is off and you have completed the backwash cleaning cycle, turn your media filter valve back to the Normal filter operating position.

**Step 6.** Press the Manual or Timer Mode function button to return to normal operation. This will turn the chlorinator and filter pump back on.



**Note:** During this process the Cell Off, Timer & Manual Mode LED lamps will flash simultaneously to warn the end user. Steps (1, 2, 3 & 5) can also be used for backwashing excess water to waste.



## FUNCTIONALITY OF YOUR CHLORINATOR (CONT)

### COVER MODE

#### For applying a Manual Pool Cover

Manual Cover Mode function reduces the chlorine output to 20%, when pressed/activated.

After applying your pool cover press the Cover Mode button. The LCD display screen will say Cover on Man. The LED lamp to which the chlorinator was in prior to selecting Cover Mode (i.e.: Manual or Timer Mode) will flash.

After removing your pool cover, switch off Cover Mode by pressing either the Timer or Manual mode buttons.



**Note: When Cover Mode is selected, the chlorinator will continue to operate in Timer or Manual mode at only 20% output.**

#### For Automatic and Motorised Pool Covers

If an automatic and motorised pool cover is fitted to the pool and wired via a micro switch to the terminal block provided in the back of the chlorinator unit, the chlorinator will automatically reduce the chlorine output to 20%. Once the pool cover is applied and the micro switch is activated, the LCD display screen will display Cover on Auto. It will continue to operate in this mode until the pool cover is removed. The corresponding LED lamp to which the chlorinator was in prior to activation will flash. When the automatic pool cover is removed the Cover on Auto message in the LCD display screen will disappear.

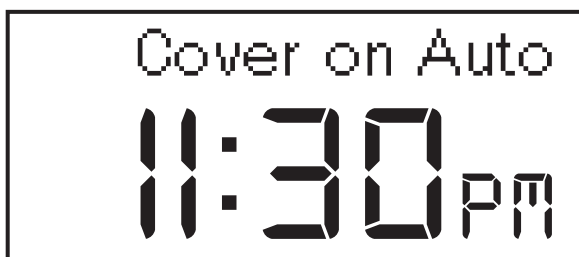

**Note: If the automatic pool cover feature is on, Manual Cover Mode will be disabled.**

## FUNCTIONALITY OF YOUR CHLORINATOR (CONT)

### SETTING THE CLOCK

Pressing the Clock button will allow you to set the real time clock. Press the up and down buttons to change the time by 1 minute. Holding either button down will change the time in 10 minute increments. The clock will begin to run when you exit this display.

You can switch between 12 & 24 hour time by pressing the up and down buttons simultaneously. The mode you select will be used wherever the time is indicated on the display.

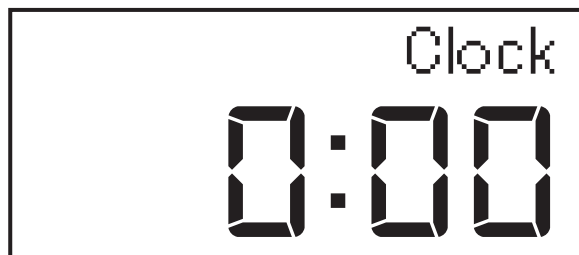

### SETTING THE TIMERS

Your chlorinator features two adjustable timers for automatic chlorination of your pool during the day. As the chlorinator cell can only operate while your filtration pump is running you need to ensure that the total daily run time will circulate all of the pool water volume through your filter at least once per day.

In addition to the filtration requirements the water temperature, numbers of bathers using the pool and amount of sunlight exposure can all affect the minimum daily run time. Please refer to the Chlorine Production section for more details.

#### Timer 1

Press **Timer 1** button once, Timer 1 Start will appear on the LCD display screen. This will default to 7am or (0700). Adjust operating time using the up & down arrows. Press **Timer 1** again, Timer 1 End will appear on the LCD display screen. This will default to 11am or (1100). Adjust operating time using the up & down arrows. To complete press any of the function buttons.



#### Timer 2

Press **Timer 2** button once, Timer 2 Start will appear on the LCD display screen. This will default to 1pm or (1300). Adjust operating time using the up & down arrows. Press **Timer 2** again, Timer 2 End will appear on the LCD display screen. This will default to 5pm or (1700). Adjust operating time using the up & down arrows. To complete press any of the function buttons. **Note: If you wish to turn Timer 2 ON or OFF, press the up & down arrows simultaneously to deactivate or activate the Timer 2 function.**



## DAY TO DAY OPERATION

Please observe the following in order to keep your chlorinator running efficiently and maintain unit life.

|                       | Free Chlorine (ppm)  | pH                               | Total Alkalinity (ppm)               | Calcium Hardness (ppm)  | Stabiliser (ppm)                        | Salt Level (ppm)                        |
|-----------------------|--|----------------------------------|--------------------------------------|---|---|---|
| <b>Ideal reading:</b> | 1 - 3  | 7.2 - 7.6                        | 80 - 120                             | Concrete/Tiled Pools: 200-275<br>Other Surfaces: 100-225          | 30 - 50                                 | > 4000                                  |
| <b>To increase:</b>   | Increase output of chlorinator, add chlorine or increase filtration time | Add Sodium Carbonate (soda ash)  | Add Sodium Bicarbonate (baking soda) | Add Calcium Chloride  | Add Cyanuric Acid                       | Add Salt                                |
| To decrease:          | Decrease output of chlorinator or reduce filtration time                 | Add Hydrochloric (Muriatic) Acid | Add Hydrochloric (Muriatic) Acid     | Partially drain & refill pool with lower hardness water to dilute | Partially drain & refill pool to dilute | Partially drain & refill pool to dilute |
| Testing freq:         | Daily  | Weekly                           | Weekly                               | Weekly  | Weekly                                  | Weekly                                  |

### FREE CHLORINE

Free chlorine is the single most important factor in pool water sanitisation. It represents the amount of disinfecting chlorine available to keep your pool sanitary and should be tested daily using a DPD test kit or similar. It is recommended that you keep the level of free chlorine in your pool between 1 and 3 ppm.

Free chlorine is consumed by sunlight and by breaking down organic material in your pool. The level which you need to maintain depends on how often your pool is used. That is, if your pool is used regularly by many bathers a higher free chlorine level will need to be maintained. If your water starts looking dull or slightly cloudy try using a higher free chlorine level. It is important that you do not allow free chlorine to become too low, otherwise you run the risk of algae growth and the pool may become unsafe to swim in.

### STABILISER (OUTDOOR POOLS ONLY)

The importance of pool stabiliser (cyanuric acid) cannot be overemphasised. It is essential in helping to retain chlorine in your pool. Chlorine is rapidly dissipated by sunlight and the use of stabiliser will reduce this loss substantially. Without stabiliser, it may be necessary to run the chlorinator for up to three times as long.

Measure the stabiliser level by using an appropriate test kit. It should be between 30 to 50 ppm. If the pool has never had stabiliser added, then 50 ppm should be added (500g per 10,000 litres, 1.1lbs per 2642gal of water). Follow the directions provided by the chemical supplier for dosing instructions. Measure the stabiliser level after backwashing and correct if necessary.

### PH AND TOTAL ALKALINITY

A correct pH level must be maintained to prevent problems such as black spot, staining and cloudy water. An incorrect pH level can damage the pool. Correct pH levels are as follows:

- Concrete & Tiled Pools: 7.4 - 7.6
- Other Surfaces: 7.2 - 7.6

If you allow the pH level to rise to 8.0 or above the chlorine required could be as much as three times the normal amount due to the chlorine being less active at high pH levels. To lower the pH level, add hydrochloric (muriatic) acid. To raise the pH level, add sodium carbonate (soda ash).

Total alkalinity should not be confused with pH, although the two are closely related. Total alkalinity determines the speed and ease of pH change. Having the total alkalinity within the recommended values buffers the pool water against rapid fluctuations in pH. The ideal range is 80 to 120 ppm, or as recommended by your pool professional. To lower the total alkalinity, add hydrochloric acid (a little at a time). To raise the total alkalinity, add sodium bicarbonate (baking soda). Please handle acid with caution and follow the chemical supplier's instructions for dosing your pool with Acid.

You should use a test kit which includes a test for total alkalinity. Low total alkalinity can cause unstable pH levels, which can cause staining, etching and corrosion of metals. High total alkalinity will cause consistently high pH levels and increase cell scaling.

## CALCIUM HARDNESS



**Note: In areas with hard water, your chlorinator may need occasional manual cleaning**

Calcium hardness refers to the amount of mineral calcium dissolved in your water. Water with low calcium levels will tend to dissolve calcium out of plaster, pebble, tile, stone and concrete finished pool surfaces. Water with high calcium levels can cause scale to form on pool surfaces and on your chlorinator cell. These problems can be prevented by maintaining your calcium hardness level at 200 to 275 ppm for concrete & tiled pools and 100 to 225 ppm for other inert surfaces. Calcium hardness can be increased by adding calcium chloride and lowered by partially draining and refilling the pool with low hardness fresh water.

## SALT



### WARNING:

**Some people recommend that you put salt directly in the skimmer box. This is a very poor practice as it allows very high concentrations of salt to be passed through your filtration and other pool equipment.**

Salt is the essential element by which your chlorinator operates. Insufficient salt means insufficient chlorine production; this simple rule governs the total operation of your ProMatic. A minimum salt level of 4000 ppm is required at all times.

### RECOMMENDED SALT LEVEL RANGE: 4000 - 6000ppm

Salt is not used up in the process of producing chlorine or by evaporation. Salt is only lost through backwashing, splash-out, overflow or leakage from the pool or plumbing. Heavy rains can also rapidly dilute the salt solution in your pool. Cold pool water has a lower conductivity which reduces the ability of the cell to carry electrical current and may lead to a reduction in chlorine output, so a higher salt level may be required in these conditions.

Your chlorinator has a built in cell output reduction and warning system which will minimise the damage resulting from insufficient salt levels. However, continuously running the chlorinator under low salt conditions can damage the coating on the cell plates and is not covered under warranty. Please ensure that adequate salt levels are maintained all year round.

As the cell reaches the end of its life the electrical current draw will drop resulting in a low salt warning, C2 Error Code, (even if the salt level is above the recommended minimum). To keep the cell operating you will need to increase the salt level. However, there will come a time when the cell will not respond to extra salt and replacement will be required.

## PHOSPHATES

Phosphates can enter your pool water from various sources such as fertilisers and ground water runoff. They can make algae control more difficult and increase the amount of sanitiser required. If you are having trouble controlling algae and maintaining an adequate free chlorine level, despite the pool water being correctly balanced, a test for phosphates may be beneficial. If phosphate levels are above 1 ppm (1000 ppb) the pool should be treated with a phosphate precipitating product or, in severe cases, the pool water should be drained and refilled with fresh water until the phosphate level has been reduced below 300 ppb.

## MANUAL CLEANING YOUR CELL

In hard water environments it may be necessary to manually clean the cell. For this a blanking cap (Davey part Q2358BK) will need to be used and purchased from your Davey Dealer or agent. To clean the cell disconnect your chlorinator from power, close any isolation valves and remove your chlorinator from the pool return line by undoing the unions (taking care not to lose the o-rings). Take the blanking cap and screw it down tightly so that it blocks the end port.

Add one part hydrochloric acid to ten parts water in a suitable container. Alternatively, a commercial cell cleaning solution may be used. **NEVER** use concentrated acid to clean your cell. Place the chlorinator on a suitable surface that allows easy access to the side port such that the solution can be poured safely into the cell. Be careful not to splash the solution. Fill until the cell plates are completely covered. Take care when doing this as the solution can foam and create a spill which must be cleaned up by dilution. Once all the scale has dissolved empty the cell appropriately and then rinse it out with a hose before undoing the blanking cap.



### WARNING:

**Follow safety instructions provided with the Hydrochloric Acid or cleaning solution. When handling Hydrochloric Acid, the use of eye protection, mask and gloves are highly recommended. Extreme cautions should be taken whenever handling Hydrochloric Acid or Cell Cleaning Solution.**



### IMPORTANT:

**KEEP BARE HANDS AWAY FROM POOL ACID AND ALWAYS USE CAUTION WHEN HANDLING POOL CHEMICALS.**

## CHLORINE PRODUCTION

Your chlorinator can produce up to a maximum of 24 grams - (0.0529 lbs) model (DAMC24G) per hour in pool water with a salt level greater than 4000 ppm (and can even run in sea water). It must be run daily to generate sufficient chlorine to sanitise the pool. During summer this will be for approximately eight hours per day, preferably in two periods at morning and night. For outdoor pools night time is preferred because chlorine dissipates rapidly in direct sunlight. If these times are observed, and the cell is functioning correctly, your pool should have sufficient chlorine when tested in the morning.

### CELL OUTPUT

Your chlorinator has been designed to take much of the guess work out of getting your sanitiser settings right. Simply enter your pool size into the chlorinator and an optimised cell output (in grams per hour) will be produced. For pools larger than 125kL (33.0kgal) please select the maximum pool size setting. As chlorine demand is also strongly affected by water temperature, the chlorinator will monitor the water temperature and automatically adjust the maximum output to suit over a 20 to 30°C range.



**Note: It is extremely important to enter your pool size correctly. Selecting too small a pool size could mean consistently low chlorine levels.**

The following table illustrates the cell output (in grams of chlorine per hour) for a range of typical pool sizes and water temperatures based on an eight hour run time.

For the chlorinator the output is limited to 24 grams per hour.

| Pool Size (kL)        | 5    | 10   | 15   | 20   | 25   | 30   | 35   | 40   | 45   | 50   | 55   | 60   | 65   |
|-----------------------|------|------|------|------|------|------|------|------|------|------|------|------|------|
| Cold < 20°C (68°F)    | 1.2  | 2.1  | 3.1  | 4.1  | 5.0  | 6.0  | 7.0  | 8.0  | 8.9  | 9.9  | 10.9 | 11.8 | 12.8 |
| Temperate 25°C (77°F) | 1.9  | 3.5  | 5.1  | 6.6  | 8.2  | 9.8  | 11.4 | 13.0 | 14.6 | 16.2 | 17.8 | 19.4 | 21.0 |
| Hot > 30°C (86°F)     | 2.6  | 4.8  | 7.0  | 9.2  | 11.4 | 13.7 | 15.9 | 18.1 | 20.3 | 22.5 | 24.0 | X    | X    |
| Pool Size (kL)        | 70   | 75   | 80   | 85   | 90   | 95   | 100  | 105  | 110  | 115  | 120  | 125  | 130  |
| Cold < 20°C (68°F)    | 13.8 | 14.8 | 15.7 | 16.7 | 17.7 | 18.6 | 19.6 | 20.6 | 21.6 | 22.5 | 23.5 | 24.0 | X    |
| Temperate 25°C (77°F) | 22.5 | 24.0 | X    | X    | X    | X    | X    | X    | X    | X    | X    | X    | X    |

For large pools where X is listed in the above table, the chlorine demand will require the daily run time to be longer than eight hours. The following table illustrates the **estimated daily run time required (in hours)** for large pools with cell production set to 100%.

| Pool Size (kL)        | 60   | 70   | 80   | 90   | 100  | 110  | 120  | 130  | 140  | 150  | 160  | 170  |
|-----------------------|------|------|------|------|------|------|------|------|------|------|------|------|
| Cold < 20°C (68°F)    | 8    | 8    | 8    | 8    | 8    | 8    | 8    | 8.5  | 9.1  | 9.7  | 10.3 | 10.9 |
| Temperate 25°C (77°F) | 8    | 8    | 8    | 8.5  | 9.4  | 10.2 | 11.0 | 11.9 | 12.7 | 13.5 | 14.4 | 15.2 |
| Hot > 30°C (86°F)     | 8    | 8.9  | 10.0 | 11.1 | 12.2 | 13.3 | 14.4 | 15.4 | 16.5 | 17.6 | 18.7 | 19.8 |
| Pool Size (kL)        | 180  | 190  | 200  | 210  | 220  | 230  | 240  | 250  | 260  | 270  | 280  | 290  |
| Cold < 20°C (68°F)    | 11.5 | 12.1 | 12.6 | 13.2 | 13.8 | 14.4 | 15.0 | 15.6 | 16.2 | 16.8 | 17.4 | 18.0 |
| Temperate 25°C (77°F) | 16.0 | 16.9 | 17.7 | 18.5 | 19.4 | 20.2 | 21.0 | 21.9 | 22.7 | 23.5 | X    | X    |
| Hot > 30°C (86°F)     | 20.9 | 21.9 | 23.0 | X    | X    | X    | X    | X    | X    | X    | X    | X    |
| Pool Size (kL)        | 300  | 310  | 320  | 330  | 340  | 350  | 360  | 370  | 380  | 390  | 400  | 410  |
| Cold < 20°C (68°F)    | 18.6 | 19.2 | 19.8 | 20.4 | 21.0 | 21.6 | 22.2 | 22.8 | 23.4 | 24   | X    | X    |

FOR POOLS WHERE X IS LISTED IN THE ABOVE TABLE, CHLORINE DEMAND EXCEEDS THE CAPACITY OF THIS MODEL AND EITHER A HIGHER OUTPUT CHLORINATOR OR MULTIPLE CHLORINATORS SHOULD BE MANIFOLDED AND FITTED.

## DAILY RUN TIME

As chlorination can only occur while your filtration pump is running, you need to ensure that the total pump run time is long enough to circulate all of the water in your pool through the filter at least once per day.

Take for example, a 50 kilolitre pool running with a 250 litre per minute pump.  $50,000 \div 250 = 200$  minutes. That means a minimum run time of 3 hours and 20 minutes per day.

Sunlight exposure and water temperature will also greatly affect how long your chlorinator needs to be run each day. During summer we recommend that you run your chlorinator for eight hours per day, whereas during winter approximately four to six hours should provide enough chlorine. Without sufficient filtration and chlorination, your pool will never function correctly. In extremely hot weather or during periods when several bathers are using the pool, the running time may need to be extended or the cell production percentage increased.



**Note: Your ProMatic chlorination cell guarantee is for a set number of hours (10,000) running the cell, which is monitored by your chlorinator. For typical installations with a run time of eight hours per day this will extend to approximately three (3) years, however longer run times will reduce the expected life of the cell.**

After testing your pool water you may find your chlorine level to be too high, that is, greater than 3 ppm. To determine if this is the case, run the chlorinator for the suggested run time and test your pool water on the morning after operation. If your chlorine test shows a high level of chlorine, you can reduce the cell production percentage or alternatively reduce the run time. Test your chlorine level again the following morning at around the same time. If your chlorine level is still high, repeat the above process until the correct level is obtained, ensuring that your run time is still long enough to filter all of the pool water within a 24 hour period. If the level is too low either increase the cell production percentage or set a longer run time.

For variable speed and low speed pumps the run time will have to be longer in order to ensure all of the pool water is filtered correctly. In such cases the cell production percentage should be set quite low. Harsh local conditions such as leaf litter, traffic pollution or windborne dust may also require different running times, in which case seek advice from your pool shop. Always run the chlorinator when swimming in the pool.

## SHOCK TREATMENT

Shock treatment refers to the addition of an oxidising chemical to the pool in order to destroy the contaminants that have bonded with the free chlorine, known as combined chlorine or chloramines. Chloramines are what produce a strong “chlorine smell” and can cause irritation to the skin and eyes of bathers.

A proven way to eliminate chloramines is super chlorination. This involves raising the free chlorine level in your pool to ten times the combined chlorine level. For example, if the water has 0.5 ppm of combined chlorine, you will need to add 5 ppm of free chlorine to destroy all of the combined chlorine. To do this, either run the chlorinator for an extended period at a cell production of 100% or add either liquid or granulated chlorine to your pool.

## CHLORINE TYPES

Many chlorinator manufacturers calibrate their units to compare with 65% granulated chlorine, making it necessary to adjust their readings to a lower level in order to determine true chlorine production. The cell production percentage on your chlorinator is expressed as 100% chlorine. The comparison table below shows the performance of your chlorinator with reference to the available types of chlorine used to sanitise pools.

| ProMatic                         | 24                        |
|----------------------------------|---------------------------|
| Maximum Production of 100% Cl    | 24g/h (0.0529 lbs)        |
| Equivalent in 65% Granulated Cl  | 37g/h (0.0815 lbs)        |
| Equivalent in Liquid NaOCl (12%) | 200mL/h (0.2113 quarts/h) |
| 100% Cl Produced over 8 Hours    | 192g (0.423 lbs)          |
| Equivalent in 65% Granulated Cl  | 296g (0.652 lbs)          |
| Equivalent in Liquid NaOCl (12%) | 1600mL (1.690 quarts)     |

## TROUBLESHOOTING

If the chlorinator detects any problems during operation a message will be displayed on the LCD panel and the backlight will flash



or



or



The following is a list of potential troubleshooting issues.

| Error Message | Problem  | Action   |
|---------------|--|--|
| <b>F1</b>     | There has been a fault with the power supply.  | Call Davey   |
| <b>F2</b>     | Gas build up has been detected or there is insufficient flow through the cell. Cell and pump have shut down. | Check that the valves are open to allow flow through the cell. If using a variable speed pump, ensure that the orientation and minimum flow requirements are met. Inspect the pump and pipes for blockage or damage. Check that flow is sufficient to fill the entire cell with water. If all of the above are fine press the manual or timer mode buttons to resume chlorination. If this problem occurs frequently please contact your dealer for service. |
| <b>F3</b>     | There has been a fault with the power supply during power up.  | Call Davey   |
| <b>F4</b>     | There has been a fault with the power supply.  | Restart the unit, if this problem reoccurs, call Davey   |
| <b>F5</b>     | The power supply has overheated and the cell and pump have shut down.  | Ensure that the chlorinator is mounted in a well ventilated and shaded location. Allow some time for the unit to cool down before pressing the manual or timer mode buttons to resume chlorination.  |
| <b>C1</b>     | Chlorination has stopped because of low water flow.  | Check that the valves are open to allow flow through the cell. If using a variable speed pump, ensure that the orientation and minimum flow requirements are met. Inspect the pump and pipes for blockage or damage. Check that flow is sufficient to fill the entire cell with water. If all of the above are fine press the manual or timer mode buttons to resume chlorination. If this problem occurs frequently please contact your dealer for service. |
| <b>C2</b>     | Chlorine output is reduced due to low salt levels in the pool or low water temperature                       | Test salt levels in the pool so that the water TDS is above 4000 ppm. Ensure the cell is full and pump primed before restarting chlorination. If this fault still occurs the cell may need to be cleaned with diluted hydrochloric acid. If this message continues to occur the cell may have reached the end of its life.   |
| <b>C3</b>     | The temperature of the pool or spa water is above 40°C (104°F). Chlorination has ceased.                     | The unit will begin chlorinating again when the water temperature is below 40°C (104°F).   |

## TROUBLESHOOTING (CONT)

### Other Actions for troubleshooting

| Problem   | Action   |
|---|--|
| Chlorine level is low.  | Check the following: <ul style="list-style-type: none"><li>• Media Filter needs backwashing</li><li>• Cell production set too low</li><li>• Pool stabiliser too low</li><li>• pH too high</li><li>• Salt level too low</li><li>• Pool size set too low</li><li>• Chlorinator run time too low</li></ul>                                    |
| No chlorine production.   | Check the following: <ul style="list-style-type: none"><li>• Mains power switched on</li><li>• Cell production is set above 0%</li><li>• Not in cell off mode</li><li>• Not in timer inactive period</li><li>• Filter needs backwashing</li><li>• Pump not plugged in or faulty</li><li>• Another fault has stopped chlorination</li></ul> |
| Display is on but not responding.                                       | Restart the unit, if this problem reoccurs please contact your dealer for service.   |
| Display is not turning on.  | Check mains power. In hot climates the display may have overheated, allow it to cool down before reapplying power. If this problem reoccurs please contact your dealer for service.  |
| Chlorinator does not detect when the pool cover micro switch is closed. | Check micro switch is correctly wired across the pool blanket pins of the terminal block. Ensure the micro switch is a normally open type and is connected using adequate gauge wires of minimal length.   |



# GENERAL INFORMATION

## Common Terms

|                                 |   |
|---------------------------------|---|
| <b>Algae</b>                    | Microscopic forms of plant life which enter the pool by rain, wind and dust. There are numerous varieties; some are free floating whilst others grow on walls and in cracks and come in different colours. Some are more resistant to chemical treatment than others. |
| <b>Bacteria</b>                 | The germs that contaminate your pool. Introduced by swimmers, dust, rain and other elements.  |
| <b>Balanced Water</b>           | The correct ratios of mineral content and pH that prevent pool water from becoming corrosive or scale forming.  |
| <b>Chloramines</b>              | Compounds formed when chlorine combines with nitrogen from urine, perspiration, or other external elements. Chloramines can cause eye and skin irritation, as well as producing unpleasant odours.  |
| <b>Chlorine Demand</b>          | The amount of chlorine required to destroy germs, algae and other contaminants in the pool.   |
| <b>Chlorine Residual</b>        | The amount of chlorine remaining after chlorine demand has been satisfied. This is the reading obtained with your test kit.   |
| <b>Stabiliser/Cyanuric Acid</b> | Also known as stabiliser or conditioner. It reduces dissipation of chlorine by direct sunlight.   |
| <b>Liquid Acid</b>              | Chemical used to reduce the pH/total alkalinity in the pool water and for cleaning chlorinator cells.   |
| <b>ppb</b>                      | An abbreviation for parts per billion (1000 ppb = 1 ppm).   |
| <b>ppm</b>                      | An abbreviation for parts per million (1 ppm = 1mg/L).  |
| <b>Algaecides</b>               | Do Not use copper based Algaecides in your pool or spa water  |

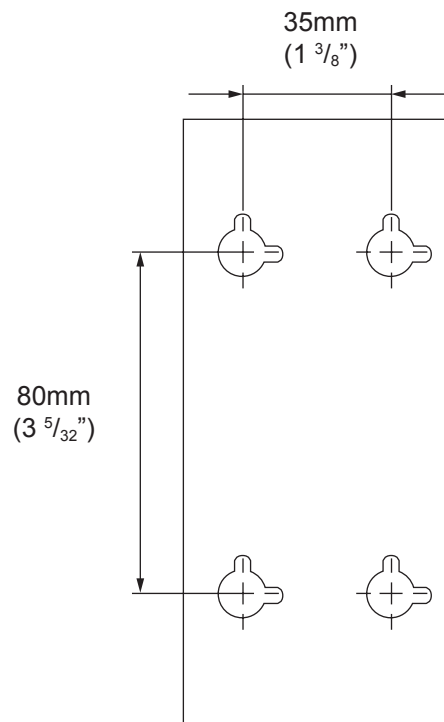



## Davey® Repair or Replacement Guarantee

In the unlikely event in Australia or New Zealand that this Davey product develops any malfunction within warranty periods beginning from the date of original purchase due to faulty materials or manufacture, Davey will at our option repair or replace it for you free of charge, subject to the conditions below.

### Davey Guarantee Period

Chlorination Cell – Three (3) Years or 10,000 operating hours  
(whichever comes first), 2 Years all other parts & 1 Year Labour

Should you experience any difficulties with your Davey product, we suggest in the first instance that you contact the Davey Dealer from which you purchased the Davey product. Alternatively you can phone our Customer Service line on 1300 367 866 in Australia, or 0800 654 333 in New Zealand, or send a written letter to Davey at the address listed below. On receipt of your claim, Davey will seek to resolve your difficulties or, if the product is faulty or defective, advise you on how to have your Davey product repaired, obtain a replacement or a refund.

Your Davey Guarantee naturally does not cover normal wear or tear, replacement of product consumables (i.e. seals, bearings or capacitors), loss or damage resulting from misuse or negligent handling, improper use for which the product was not designed or advertised, failure to properly follow the provided installation and operating instructions, failure to carry out maintenance, corrosive or abrasive water or other liquid, lightning or high voltage spikes or unauthorized persons attempting repairs. Where applicable, your Davey product must only be connected to the voltage shown on the nameplate.

Your Davey Guarantee does not cover freight or any other costs incurred in making a claim. Please retain your receipt as proof of purchase; you **MUST** provide evidence of the date of original purchase when claiming under the Davey Guarantee.

Davey shall not be liable for any loss of profits or any consequential, indirect or special loss, damage or injury of any kind whatsoever arising directly or indirectly from Davey products. This limitation does not apply to any liability of Davey for failure to comply with a consumer guarantee applicable to your Davey product under the Australian or New Zealand legislation and does not affect any rights or remedies that may be available to you under the Australian or New Zealand Consumer Legislation.

In Australia, you are entitled to a replacement or refund for a major failure and for compensation for any other reasonably foreseeable loss or damage. You are also entitled to have the goods repaired or replaced if the goods fail to be of acceptable quality and the failure does not amount to a major failure.

Should your Davey product require repair or service after the guarantee period; contact your nearest Davey Dealer or phone the Davey Support Centre on the number listed below.

For a complete list of Davey Dealers visit our website ([davey.com.au](http://davey.com.au)) or call:



Davey Water Products Pty Ltd  
Member of the GUD Group  
ABN 18 066 327 517

™ Davey is a trademark of Davey Water Products Pty Ltd.  
© Davey Water Products Pty Ltd 2014.

#### AUSTRALIA

**Davey Support Centre**  
6 Lakeview Drive,  
Scoresby, Australia 3179  
Ph: 1300 232 839  
Fax: 1300 369 119  
Website: [davey.com.au](http://davey.com.au)

#### NEW ZEALAND

**Davey Support Centre**  
7 Rockridge Avenue,  
Penrose, Auckland 1061  
Ph: 0800 654 333  
Fax: 09 527 7654  
Website: [daveynz.co.nz](http://daveynz.co.nz)

P/N 402147

\* Installation and operating instructions are included with the product when purchased new.  
They may also be found on our website.