

BARACUDA®

THE TRUSTED NAME IN POOL CARE

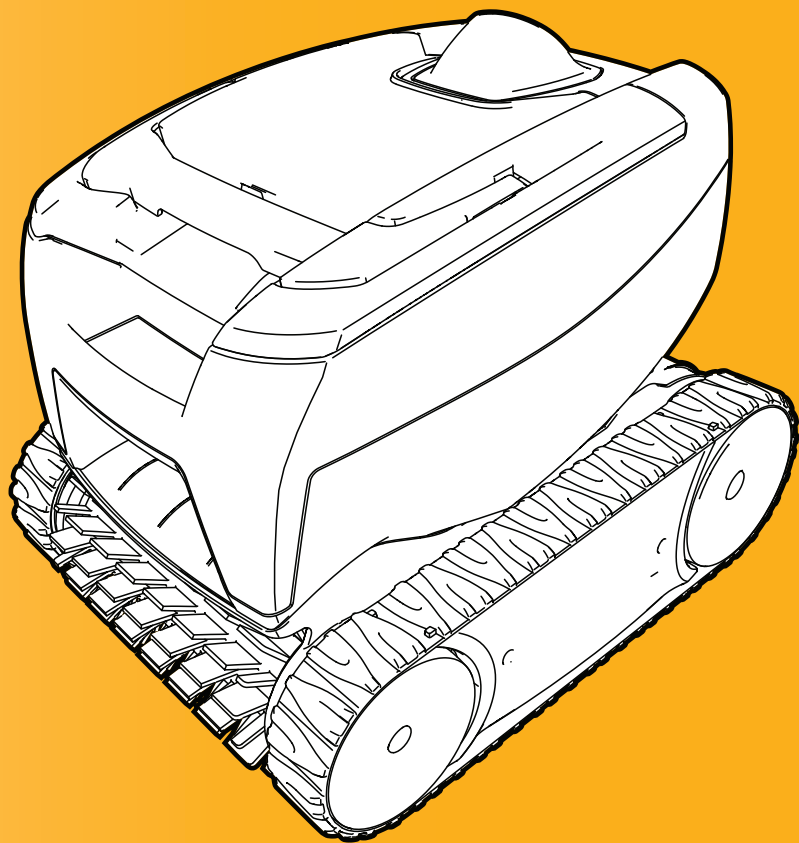

EP34--
EP35--

rova™

Robotic Pool Cleaner

Owner's Manual

Introduction

Congratulations on the purchase of your new BARACUDA® Rova™ robotic pool cleaner. Your Rova is designed and manufactured for easy installation, and years of carefree operation. Before installing the cleaner, please take a few moments to become familiar with its components and to review the items listed under Important Information.

Table of Contents

Section 1. Important Safety Instructions	3	Section 4. Maintenance	9
Section 2. Getting Started	4	4.1 Cord Tangling	9
2.1 General Specifications	4	4.2 Replacing the Brushes	9
2.2 Unpacking	4	4.3 Replacing the Track	10
2.3 Cleaner Control Unit	4	Section 5. Troubleshooting	10
2.4 Connecting the Floating Cable to the Control Box	5	5.1 Using the Information LED	10
		5.2 General Troubleshooting	11
Section 3. Operation	6		
3.1 Submerging the Cleaner	6		
3.2 Running the Cleaner	6		
3.3 Stopping the Cleaner and Removing from the Pool	7		
3.4 Rinsing the Cleaner	7		
3.5 Cleaning the Filter Canister	7		
3.6 Storing the Cleaner	8		

Suitable Pools

The BARACUDA® Rova™ is suitable for most domestic in-ground pools up to 10m x 5m.

Pool surfaces include: Concrete, pebblecrete, quartzon, fibreglass and vinyl. Not suitable for tile pools. Not suitable for above ground pools. Suitable for medium to large debris.

YOUR CLEANER HAS BEEN DESIGNED AND MANUFACTURED TO BE EASILY INSTALLED AND TO PROVIDE LOW MAINTENANCE OPERATION. A WARRANTY CARD IS SUPPLIED IN THE BOX. PLEASE GO TO BARACUDA.COM.AUTO REGISTER FOR WARRANTY.

Taking these steps will help ensure prompt warranty service, should it be required. If service is required, please contact your original dealer. If the original dealer does not perform warranty service, please visit

www.baracuda.com.au to locate an independent service company near you. If you are unable to locate a service company, please call our Baracuda Customer Service at 1300 784 423.

Section 1. Important Safety Instructions

⚠ WARNING

Failure to comply with the following warnings can result in permanent injury, electrocution or death.

PREVENT ELECTRICAL SHOCK

To reduce risk of electrical shock:

- The cleaner is to be installed in accordance with the relevant requirements of the Australian wiring rules AS/NZS 3000. Also refer to the installation instructions relating to the swimming pool equipment for which the cleaner will be an integral part. The cleaner is to be supplied through a Residual Current Device (RCD) with a rated residual operating current of 30mA.
- Do not enter pool while the robotic cleaner is in water.
- Do not bury cord. Locate cord so as to prevent it from being damaged by lawn mowers, hedge trimmers and other equipment.
- To reduce the risk of electrical shock, do not use the robotic cleaner or control box if the cord is worn or damaged. Contact Baracuda Customer care Service 1300 784 423 immediately for proper servicing and replacement of the damaged cord.
- Double insulation—For continued protection against possible electric shock, use only identical replacement parts when servicing. Do not attempt repair of the robotic cleaner, control box, power cord, or floating cable.
- Use only the power supply provided with the product.
- NEVER OPEN Control box.
- DO NOT USE AN EXTENSION CORD TO CONNECT THE UNIT TO ELECTRIC SUPPLY; PROVIDE A PROPERLY LOCATED RCD PROTECTED POWER OUTLET. THE CONTROL BOX SHOULD BE PLACED NEAR THE RCD PROTECTED GFCI POWER OUTLET POINT.

PREVENT CHILD INJURY AND DROWNING

- To reduce the risk of injury, do not permit children or persons with reduced physical, sensory or mental capabilities, or lack of experience and knowledge to operate this product.
- Do not let anyone, especially small children, sit, step, lean, or climb on any equipment installed as part of your pool's operational system.

⚠ CAUTION

Failure to comply with the following warnings could cause damage to pool equipment or personal injury.

- The robotic cleaner must be installed and operated as specified.
- This product is intended for use with permanently-installed pools. Do not use with storable pools. A permanently-installed pool is constructed in or on the ground or in a building such that it cannot be readily disassembled for storage. A storable pool is constructed so that it is capable of being readily disassembled for storage and reassembled to its original integrity.
- Clean the filter canister after each use.
- Do not use the product in your pool if the water temperature is above 35° C (95° F) or below 13° C (55° F).

⚠ CAUTION

USE OF THE BARACUDA ROBOTIC CLEANER IN A VINYL LINER POOL

Certain vinyl liner patterns are particularly susceptible to rapid surface wear or pattern removal caused by objects coming into contact with the vinyl surface, including pool brushes, pool toys, floats, fountains, chlorine dispensers, and automatic pool cleaners. Some vinyl liner patterns can be seriously scratched or abraded simply by rubbing the surface with a pool brush. Ink from the pattern can also rub off during the installation process or when it comes into contact with objects in the pool. Zodiac Group Australia Pty Ltd is not responsible for, and the Limited Warranty does not cover, pattern removal, abrasion or markings on vinyl liners.

SAVE THESE INSTRUCTIONS

Section 2. Getting Started

2.1 General Specifications

The general specifications for the cleaner are as follows:

Control box supply voltage 	100-240 VAC, 50/60 Hz; short circuit-proof safety isolating type
Output voltage	30 V DC
Installed load	100 W max
Max Total Depth	4m
Cable length	14m
Cleaner size (WxDxH)	37 x 29 x 30 cm
Weight of Cleaner	7 kg
Filtration	All-purpose filter canister. (200 micron)
Power Supply	IP45
Robotic Cleaner	IPX8

This cleaner is a double-insulated product. A double-insulated electrical appliance is one which has been designed in such a way that it does not require a safety connection to ground. The basic requirement for double-insulation is that no single failure will result in dangerous voltage becoming exposed so that it might cause an electric shock and that this is achieved by having two (2) layers of insulating material surrounding live parts or by using reinforced insulation. Therefore, devices having double-insulated construction, such as this cleaner, do not require a grounded (three-prong) plug.

2.2 Unpacking

The packaging should contain the following items:

- Baracudu robotic cleaner
- Power cord
- Control unit
- Control unit base

When unpacking the cleaner and its components:

- Check to make sure each component is in the box.
- Check cleaner and components for damage during transport.
- If there are missing parts or damage, contact Baracuda Technical Support: 1300 784 423

2.3 Cleaner Control Unit

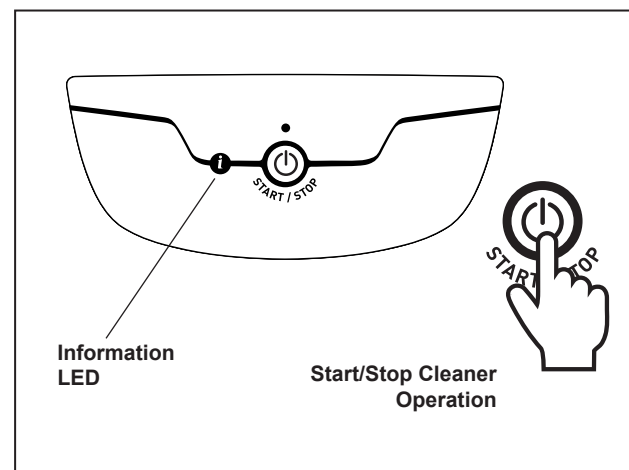

Section 2. Getting Started

2.4 Connecting the Floating Cable to the Control Box

⚠ WARNING

Failure to comply with the following warnings can result in permanent injury, electrocution or drowning.

PREVENT ELECTRICAL SHOCK

- Keep the control unit at least five 3.5m from the edge of the pool.
- The cleaner is to be installed in accordance with the relevant requirements of South African wiring rules, or in Australia within requirements of wiring rules AS/NZS 3000. Also refer to the installation instructions relating to the swimming pool equipment for which the cleaner will be an integral part. The cleaner is to be supplied through a Residual Current Device (RCD) with a rated residual operating current of 30mA.
- Do not use an extension cord to connect the control unit.
- Do not allow anyone to swim while the cleaner is in the pool.
- The control unit is water-resistant, not waterproof. In order to prevent electrocution, never submerge the control unit or leave exposed to inclement weather.

1. Unscrew the protective cap for the floating cable from the side of the control unit by turning anti-clockwise (Figure 1).

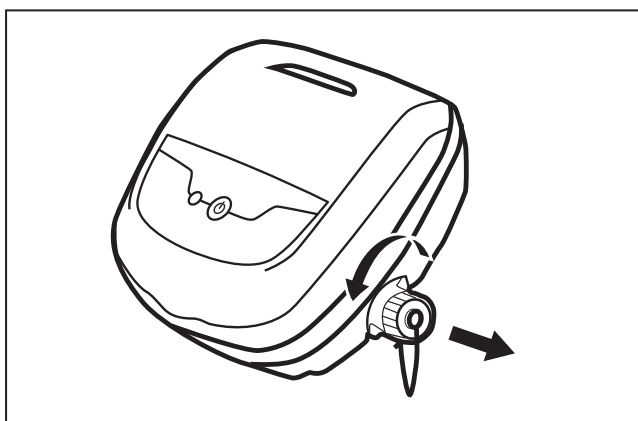

Figure 1. Remove Protective Cap

2. Align the notch in the floating cable connector with the key in the control unit, engage then turn clockwise to tighten. (Figure 2.)

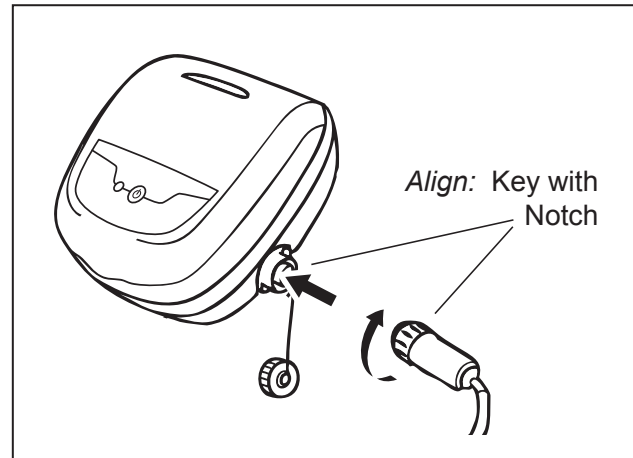
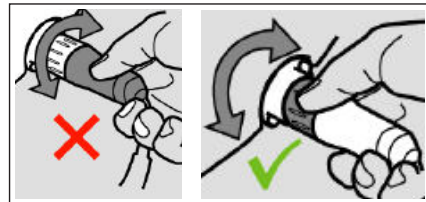

Figure 2. Connect Floating Cable

3. Plug the control unit directly into a "RCD" outlet. DO NOT use an extension cord.

NOTE: To avoid damaging the power cable, do not try to twist the entire cable housing (see below).



NOTE: To avoid exposing the power cable connector pins to water, be sure the connector is screwed in all the way and there is no gap. (see below).

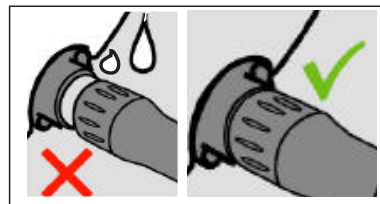

Section 3. Operation

⚠ CAUTION

To prevent damage to the cleaner, be sure to adhere to the following guidelines:

- Remove the cleaner from the pool after the cleaning cycle is completed and store on the caddy out of direct sunlight or inclement weather.
- Take additional care when lifting the cleaner out of the pool. It becomes heavier when filled with water.
- Always remove the cleaner from pool when super chlorinating or adding acid.
- Do not handle cleaner while it is in operation.

IMPORTANT

- Always make sure the cleaner head is fully submerged before you begin operation.
- Clean the filter canister after each cleaning cycle.
- Do not leave your cleaner in the pool on a permanent basis.
- At the end of each cycle, remove the cleaner from the pool. Start at the cleaner head and untangle any coils in the cable before storing the cleaner.
- Baracuda recommends only three cleaning cycles per week.

The Baracuda robotic cleaner includes a safety feature that automatically stops the cleaner if it is powered on but not submerged in water. For pools equipped with a beach area, this safety feature is programmed to drive the cleaner in reverse and back into the pool when the impeller is out of the water.

3.1 Submerging the Cleaner

1. Submerge cleaner vertically (1) and hold it under the surface, moving gently from side to side (2) until the bubbles stop to remove any air trapped inside (Figure 3).
2. When the bubbles stop, allow the cleaner to sink to the bottom of the pool.
3. Verify the cleaner is sitting on the bottom of the pool. Remove additional air if the cleaner is still floating.

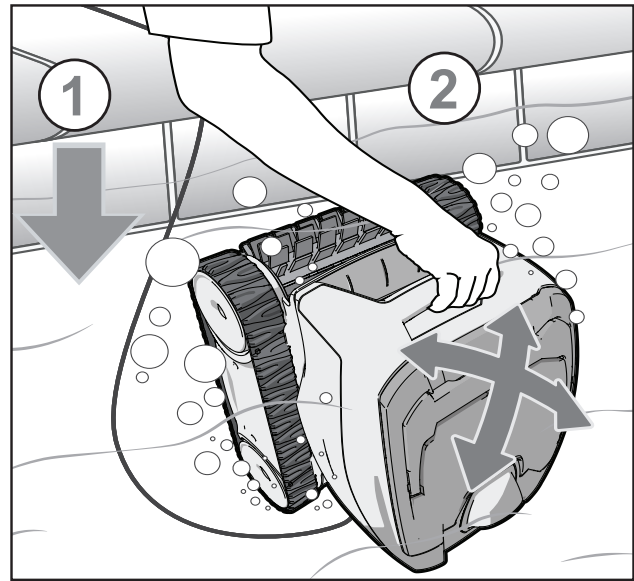

Figure 3. Submerge and Remove Trapped Air

4. Spread the floating cable over the pool, making sure there are no kinks or coils in the cable (Figure 4). Spread all of the floating cable carefully in the pool, ensuring there are no kinks or coils.

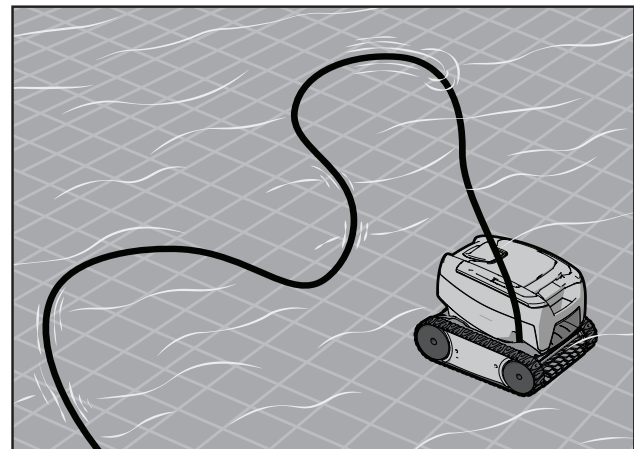

Figure 4. Spread Floating Cable Over the Pool

3.2 Running the Cleaner

Begin Cleaning:

- Press Start/Stop button on control unit to begin operation.

Section 3. Operation

3.3 Stopping the Cleaner and Removing from the Pool

1. Press Start/Stop button on control unit to interrupt operation.
2. When the cleaner is within arm's reach, use the handle to lift it from the water (Figure 5). Never lift the cleaner out of the pool by the floating cable.

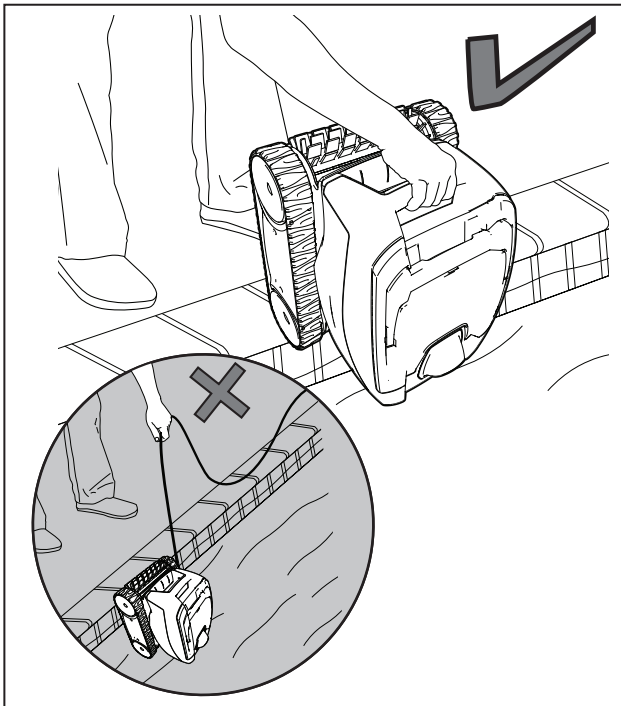

Figure 5. Lift Cleaner From Pool with Handle

3. Hold the cleaner vertically over the pool surface to drain water before removing (Figure 6).

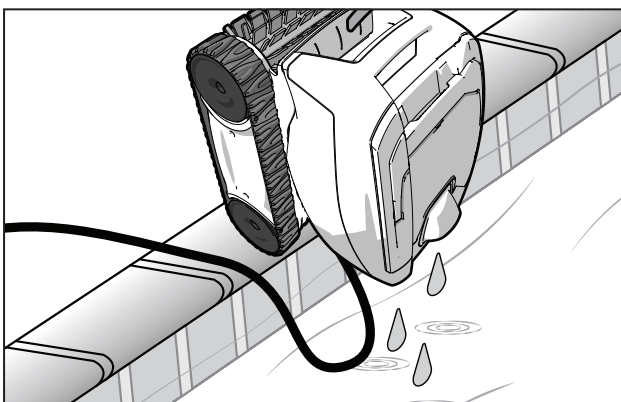

Figure 6. Drain Water from the Cleaner

3.4 Rinsing the Cleaner

Rinse the cleaner after every cleaning cycle. Use slightly soapy clean water, then rinse generously with clean water. Do not use solvents such as trichlorethylene or its equivalent. Do not let your cleaner dry in direct sunlight near the pool.

3.5 Cleaning the Filter Canister

Empty the canister as soon as the cycle ends.

⚠ WARNING

To avoid electric shock and other hazards which could result in permanent injury or death, disconnect (unplug) the cleaner from the power source before performing any cleaning and maintenance.

1. Unplug power to the cleaner at the control unit. Turn off power then unplug the control unit from the power source.
2. Release the canister handle by rotating handle upwards (Figure 7).

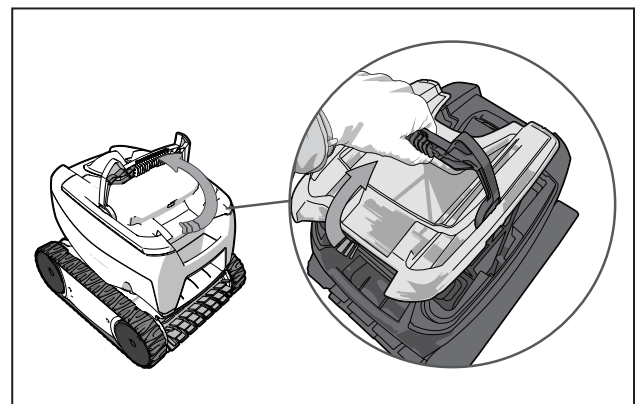

Figure 7. Release Filter Canister Handle

Section 3. Operation

3. Grasp the handle and lift up to remove the filter canister (Figure 8).

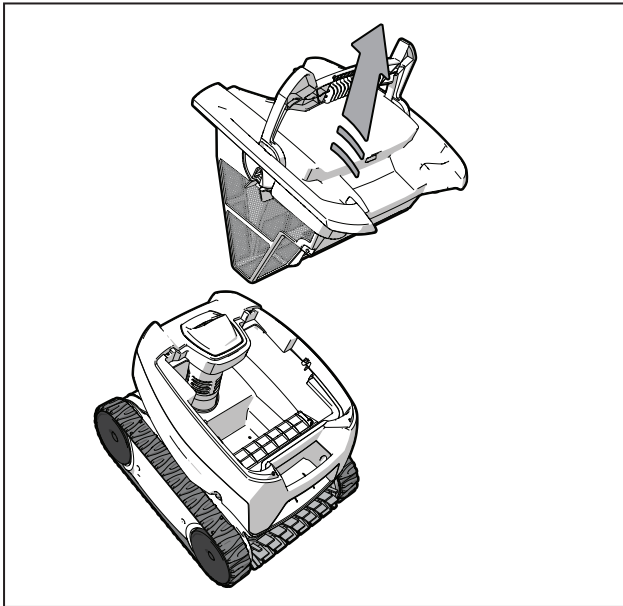

Figure 8. Remove the Filter Canister

4. Press the interior latch and remove the filter canister lid. See Figure 9.

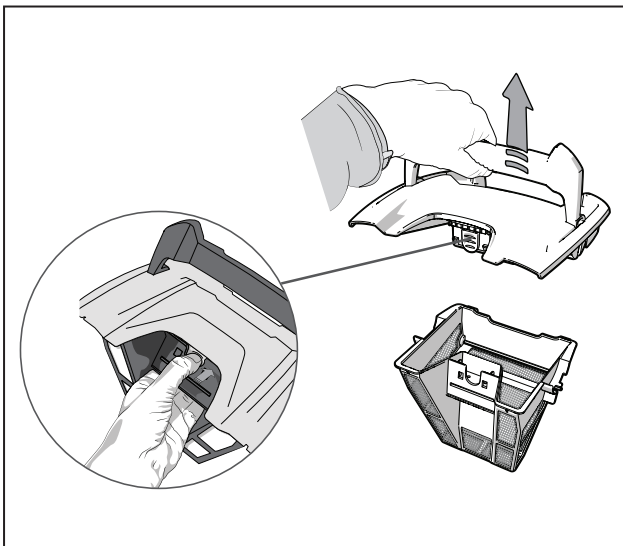

Figure 9. Remove Filter Canister Lid

5. Using a hose with clean water, rinse the filter canister and lid to remove all debris (Figure 10).

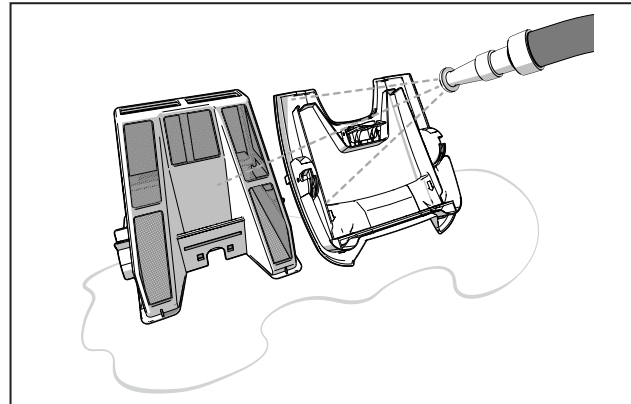

Figure 10. Rinse the Filter Canister

6. Let the lid and filter canister dry.
7. Replace lid on the canister and then replace canister back into the cleaner body.
8. Plug the power cord back into the control unit and store the cleaner out of direct sunlight for next use.

3.6 Storing the Cleaner

1. Untangle any kinks and coils from the floating cable starting at the cleaner head.
2. Store the cleaner out of direct sunlight.

Section 4. Maintenance

⚠ WARNING

To avoid electric shock and other hazards which could result in permanent injury or death, disconnect (unplug) the cleaner from the power source before performing any cleaning and maintenance.

4.1 Cord Tangling

IMPORTANT

The power cable may become tangled if correct procedure is not followed after each cleaning cycle.

Do not leave the cleaner unattended for prolonged periods and follow the procedure below to avoid excessive tangling.

After every cleaning cycle:

1. Unplug power to the cleaner at the control unit.
2. Remove the cleaner from the pool and untangle all kinks and coils in the floating cable starting at the cleaner head (Figure 13).
3. Plug power cord back into control unit and store cleaner out of direct sunlight for next use.

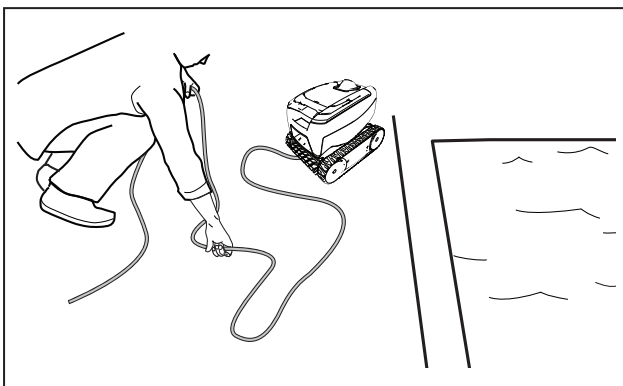

Figure 13. Untangle the Floating Cable

4.2 Replacing the Brushes

The cleaner is fitted with a scrubbing brush in front. There are "wear" indicators (Figure 14) on the brushes. To maintain cleaner performance at its best you need to replace the brush as soon as one of the wear indicators has been reached (even if the blade wear is not even). Baracuda recommends that you replace the brush every two (2) years.

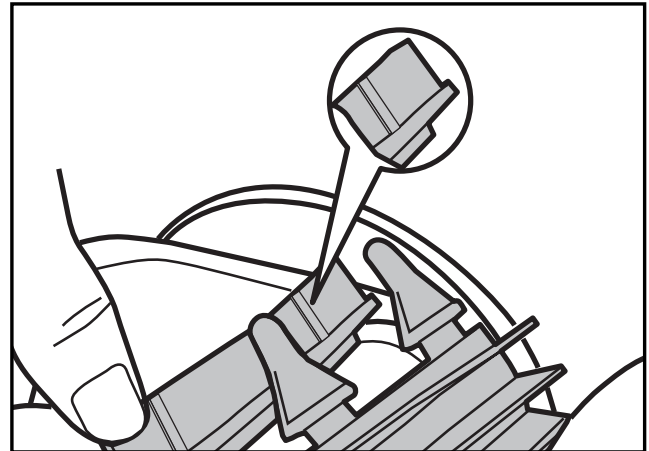

Figure 14. Wear Indicators

1. Separate the edges of the brush, undo the tabs, and remove the worn brush.
2. Position the new brush underneath the roller with the spikes facing downwards. Refer to Figure 15.

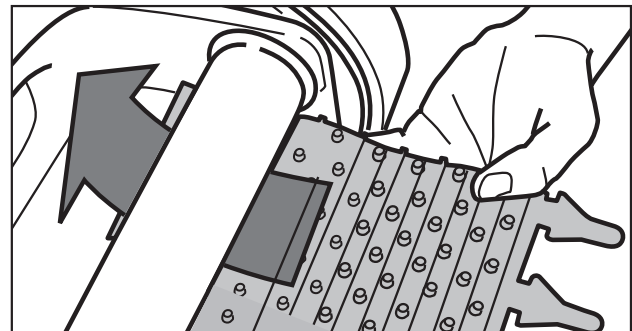

Figure 15. Position the New Brush on Roller

3. Thread each tab into the slot provided and gently feed it through until the heel comes out at the other side of the slot. Refer to Figure 16.

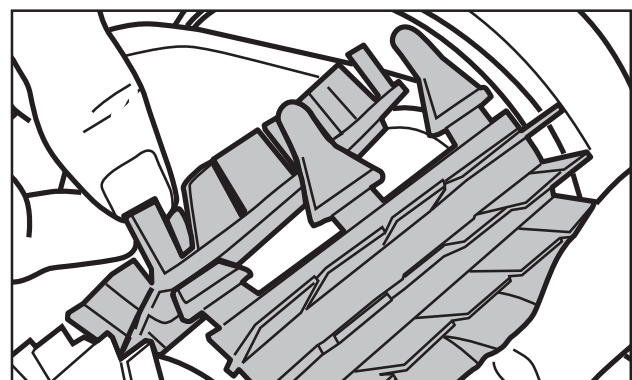

Figure 16. Pull Tabs Through Each Slot

Section 4. Maintenance

- Use scissors to cut the tabs so they are no higher than the spikes as shown in Figure 17.

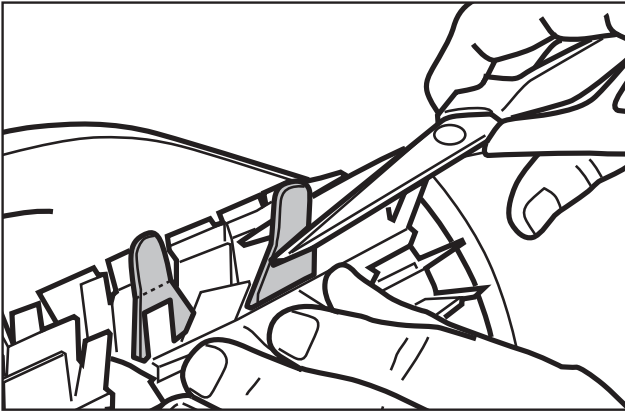

Figure 17. Cut Tabs

4.3 Replacing Tracks

- Stand the cleaner on its side (Figure 18).

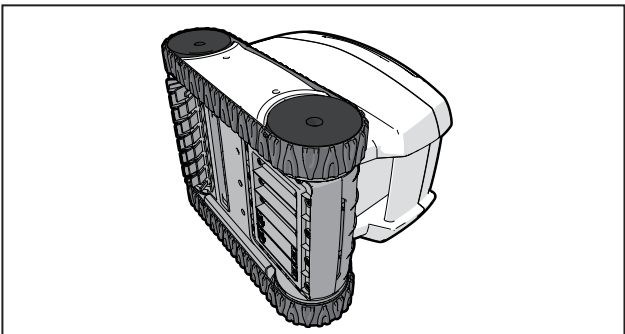

Figure 18. Stand Cleaner on its Side

- Starting at one of the wheels, pull on the inside of the track to separate the tyre lip from the wheel. Remove the track from the cleaner.
- To install a new track, place the inside rib of the track into the groove in the first wheel (Figure 19).

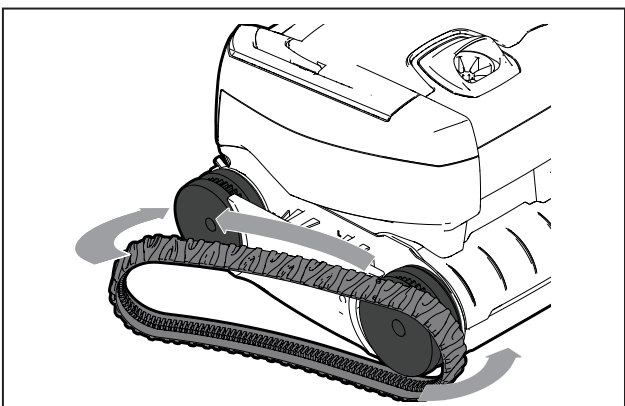

Figure 19. Stretch Track Around Wheels

- Stretch the track around the second wheel, (see Figure 19). Push and position the rib of

the track so that the track is seated properly in the groove of the wheel.

- Verify the rib of the track is positioned properly within the groove of each of the two wheels. If necessary, turn the wheels gently to seat track.

Section 5. Troubleshooting

5.1 Using the Information LED

The information LED  on the control unit flashes in a specific sequence to indicate one of three possible cleaner malfunctions.

LED Flashing	Solution
1 Flash LED flashes once with one second interval.	Unplug the floating cable from the control unit and reconnect. If the problem persists, contact Baracuda Customer Service at 1300 784 423
2 Flashes LED flashes twice with one second interval	Turn cleaner wheels to ensure they are not jammed. Check brushes for debris. Start a new cleaning cycle. If the problem persists, contact Baracuda Customer Service at 1300 784 423
3 Flashes LED flashes three times with one second interval	Check the pump axis for debris. Check propellor for debris. Clean the filter. Start a new cleaning cycle. If the problem persists, contact Baracuda Customer Service at 1300 784 423
4. Flashes LED flashes four times with one second interval	<ul style="list-style-type: none"> Temperature too high in the control box: <ul style="list-style-type: none"> -Preferably install the box in a shaded location. -Allow the box to cool before starting a new cycle. General cleaner surge current. Check the solutions for flashing indicators No.2 and No.3:
4. Flashes LED flashes five times with one second interval	•The cleaner may be stuck in one area of the pool. Re-start a cycle or check the solutions for the flashing indicators No.2

Section 5. Troubleshooting

5.2 General Troubleshooting

The following table lists some of the common symptoms, causes, and solutions for correcting cleaner operation problems.

Problem	Cause	Solution
The Information LED flashes just after start (either pressing Power or Cycle button for less than 20 seconds).	Floating cable may not be plugged into the control unit correctly.	Unplug floating cable from the control unit and reconnect.
	Cleaner may not be fully submerged.	Remove cleaner from the pool and re-submerge, see <i>Submerging the Cleaner</i> .
	Propellor may be jammed and not turning correctly.	Contact Baracuda Customer Service at 1300 784 423
	Wheels may be jammed and not turning correctly.	Contact Baracuda Customer Service at 1300 784 423
The Information LED flashes during the cleaning cycle.	Cleaner may be sucking air (lights will appear after 60 seconds air intake)	Remove cleaner from the pool and re-submerge, see <i>Submerging the Cleaner</i> .
The cleaner does not stay firmly on the pool bottom.	There is air in the appliance casing.	Remove cleaner from the pool and re-submerge, see <i>Submerging the Cleaner</i> .
	The filter canister is full or dirty.	Clean the filter canister, see <i>Cleaning the Filter Canister</i> .
The cleaner does not or no longer climbs the pool walls.	The filter canister is full or dirty.	Clean the filter canister, see <i>Cleaning the Filter Canister</i> .
	Walls of pool are slippery or slimy Although the water seems clear, microscopic algae, invisible to the human eye, may be present in the pool. As a result the pool sides become slippery and prevent the cleaner from climbing. Check tracks for wear and replace as necessary.	Do a shock chlorination treatment to reduce the pH levels in the pool. DO NOT leave the cleaner in the pool during this treatment.
On startup the cleaner does not move.	No power supply to the cleaner.	Check that the outlet to which the control unit is connected is receiving electricity.
	Unit is turned OFF.	Turn the tracks then disconnect the control unit and wait at least 20 seconds before reconnecting. If the problem persists, contact Baracuda Customer Service at 1300 784 423
Cable is tangling in the pool	Too much cable length in the water.	Verify the floating cable enters the water near the middle of the pool length, see <i>Cord Tangling</i> . Spread all of the floating cable carefully in the pool, ensuring there are no kinks or coils
The cleaner is not cleaning effectively.	The brushes have become smooth or the "wear" indicator shows.	Replace the brushes following the procedure in <i>Replacing the Brushes</i> .
	Filter canister is full or dirty.	Clean the filter canister following the procedure in <i>Cleaning the Filter Canister</i> .
	Floating cable is excessively coiled or kinked.	Make sure the floating cable is spread out over the pool. Ensure the cable is not too tightly wrapped or coiled when storing. If the problem persists, lay the cable straight in the sun to relax it and remove kinks. Follow the procedure in <i>Cord Tangling</i> to avoid and correct tangled cord.
	Tyre track is coming off the wheels	Verify track is properly inserted in the wheel groove. If problem persists, replace the tyre track, see <i>Replacing the Track</i> .

Exceptional After Sales Support

We have a trained team on hand to help walk you through how to set up your cleaner and equipment. For installation and troubleshooting questions, please directly contact BARACUDA® After Sales.

And don't forget to register your product online for warranty (see Warranty Card inside the pack).

Happy Swimming!

For more information visit www.baracuda.com.au
or call **1300 784 423**

BARACUDA®
THE TRUSTED NAME IN POOL CARE

Baracuda is a registered trademark of
Zodiac Group Australia Pty Ltd
ABN 87 002 641 965
219 Woodpark Rd, Smithfield, NSW 2164 Australia
Tel: 1300 784 423 www.baracuda.com.au

© Copyright Zodiac Australia Ltd 2019