

## **Zodiac FloPro E3 3-Speed Variable Pump**

### **⚠ WARNING**

**FOR YOUR SAFETY** - This product must be installed and serviced by a contractor who is licensed and qualified in pool equipment by the jurisdiction in which the product will be installed where such state or local requirements exist. The maintainer must be a professional with sufficient experience in pool equipment installation and maintenance so that all of the instructions in this manual can be followed exactly. Before installing this product, read and follow all warning notices and instructions that accompany this product. Failure to follow warning notices and instructions may result in property damage, personal injury, or death. Improper installation and/or operation will void the warranty.

Improper installation and/or operation can create unwanted electrical hazard which can cause serious injury, property damage, or death.



**ATTENTION INSTALLER** - This manual contains important information about the installation, operation and safe use of this product. This information should be given to the owner/operator of this equipment.

# Table of Contents

<b>Section 1. Important Safety Instructions .....3</b>	<b>Section 5. Service and Maintenance.....8</b>
1.1 Safety Instructions..... 3	5.1 Routine Maintenance ..... 8
1.2 Pool Pump Suction Entrapment Prevention Guidelines ..... 5	<b>Section 6. Troubleshooting and Repair.....9</b>
<b>Section 2. General Description .....5</b>	6.1 Troubleshooting..... 9
2.1 Introduction..... 5	6.2 Fault Codes ..... 10
2.2 Description ..... 5	6.3 Service Technician Maintenance ..... 10
<b>Section 3. Installation Information.....5</b>	<b>Section 7. Product Specifications and Technical Data .....14</b>
3.1 Plumbing ..... 5	7.1 Replacement Parts List ..... 14
3.2 Electrical Installation..... 6	7.2 General Specifications ..... 14
3.3 Conduct Pressure Testing ..... 6	7.3 Exploded View..... 15
<b>Section 4. Operation.....7</b>	
4.1 Start-up..... 7	
4.2 Operational Controls ..... 7	

## EQUIPMENT INFORMATION RECORD

DATE OF INSTALLATION \_\_\_\_\_

INSTALLER INFORMATION \_\_\_\_\_

INITIAL PRESSURE GAUGE READING (WITH CLEAR FILTER) \_\_\_\_\_

PUMP MODEL \_\_\_\_\_ HORSEPOWER \_\_\_\_\_

NOTES:  
\_\_\_\_\_  
\_\_\_\_\_  
\_\_\_\_\_

# Section 1. Important Safety Instructions

## READ AND FOLLOW ALL INSTRUCTIONS

### 1.1 Safety Instructions

All electrical work must be performed by a licensed electrician and conform to all national, state, and local codes. When installing and using this electrical equipment, basic safety precautions should always be followed, including the following:

#### **WARNING**

**RISK OF SUCTION ENTRAPMENT HAZARD, WHICH, IF NOT AVOIDED, CAN RESULT IN SERIOUS INJURY OR DEATH.** Do not block pump suction, as this can cause severe injury or death. Do not use this pump for wading pools, shallow pools, or spas containing bottom drains, unless the pump is connected to at least two (2) functioning suction outlets. Drain covers must be certified to the latest published edition of ANSI/ASME A112.19.8.

#### **WARNING**

To reduce the risk of injury, do not permit children to use this product.

#### **WARNING**

To reduce the risk of property damage or injury, do not attempt to change the backwash (multiport, slide, or full flow) valve position with the pump running.

#### **WARNING**

Incorrectly installed equipment may fail, causing severe injury or property damage.

#### **WARNING**

The pump is for fixed installations only and to be used in conjunction with swimming pool equipment (e.g. filters).

The pump is to be installed in accordance with the relevant requirements of the Australian wiring rules NS/NZS 3000.

Also refer to the installation instructions relating to the swimming pool equipment for which the pump will be an integral part.

The pump is to be supplied through a residual current device (RCD) with a rated residual operating current of 30mA.

If the supply cord is damaged, it must be replaced by the manufacturer or its service agent or similarly qualified person in order to maintain proper safety conditions.

## WARNING

To minimize the risk of severe injury or death, the filter and/or pump should not be subjected to the piping system pressurization test.

Local codes may require the pool piping system to be subjected to a pressure test. These requirements are generally not intended to apply to the pool equipment such as filters or pumps.

Zodiac® pool equipment is pressure tested at the factory.

However, if the WARNING cannot be followed and pressure testing of the piping system must include the filter and/or pump, **BE SURE TO COMPLY WITH THE FOLLOWING SAFETY INSTRUCTIONS:**

- Check all clamps, bolts, lids, lock rings and system accessories to ensure they are properly installed and secured before testing.
- **RELEASE ALL AIR** in the system before testing.
- Water pressure for test must **NOT EXCEED 35 PSI**.
- Water temperature for test must **NOT EXCEED 100°F (38°C)**.
- Limit test to 24 hours. After test, visually check system to be sure it is ready for operation.

**NOTICE:** These parameters apply to Zodiac equipment only. For non-Zodiac equipment, consult equipment manufacturer.

## WARNING

Chemical spills and fumes can weaken pool/spa equipment. Corrosion can cause filters and other equipment to fail, resulting in severe injury or property damage. Do not store pool chemicals near your equipment.

## CAUTION

**Do not start pump dry!** Running the pump dry for any length of time will cause severe damage and will void the warranty.

## CAUTION

This pump is for use with permanently installed pools and may also be used with hot tubs and spas, if so marked. Do not use with storable pools. A permanently installed pool is constructed in or on the ground or in a building such that it cannot be readily disassembled for storage. A storable pool is constructed so that it may be readily disassembled for storage and reassembled to its original integrity.

**SAVE THESE INSTRUCTIONS**

## 1.2 Pool Pump Suction Entrapment Prevention Guidelines

### **⚠ WARNING**

Pump suction is hazardous and can trap and drown or disembowel bathers. Do not use or operate swimming pools, spa, or hot tubs if a suction outlet cover is missing, broken, or loose. The following guidelines provide information for pump installation that minimizes the risk of injury to users of pools and spas. Refer to Australian Standard 1926.3 for further information.

### **⚠ WARNING**

The pump is not intended for use by young children or infirm persons unless they have been adequately supervised by a responsible person to ensure that they can use the pump safely. Young children should be supervised to ensure that they do not play with the pump.

## Section 2. General Description

### 2.1 Introduction

This manual contains information for the proper installation, operation, and maintenance of the Zodiac E3 variable speed pump. Procedures in this manual must be followed exactly. To obtain additional copies of this manual, contact Zodiac® Customer Service at 1.800.688.552. For address information, see the back cover of this manual.

### 2.2 Description

The E3 is a variable-speed pump that can be run from 1000 RPM to 2850 RPM. The pump provides three separate program modes to vary the speed settings that are accessible by a simple touch of a button. This allows for simple operations that can greatly reduce operating costs at a reasonable investment.

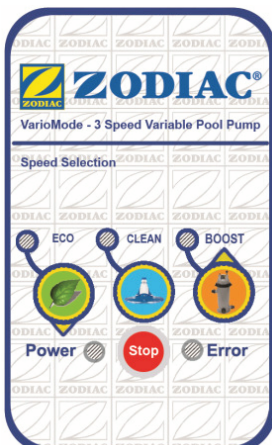

**EcoMode:** 1400 RPM  
**CleanMode:** 2150 RPM  
**BoostMode:** 2850 RPM

**NOTE:** The recommended speed setting is 1400 RPM.

## Section 3. Installation Information

### 3.1 Plumbing

#### 3.1.1 Preparation Information

1. Upon receipt of the pump, check the carton for damage. Open the carton and check the pump for concealed damage, such as cracks, dents or a bent base. If damage is found, contact the shipper or distributor where the pump was purchased.
2. Inspect the contents of the carton and verify that all parts are included, see Section 7.1, Replacement Parts List and Exploded View.

#### 3.1.2 Pump Location

1. Zodiac recommends installing the pump within three hundred millimetres (300mm) above water level. The pump should not be elevated more than a metre above the water level of the pool. A check valve is recommended on the suction line of the pump.
2. If the pump is located below water level, isolation valves must be installed on both the suction and return lines to prevent back flow of pool water during any routine or required servicing.

**NOTE** When the pool equipment is located below the pool surface a leak can result in large scale water loss or flooding. Zodiac cannot be responsible for such water loss or flooding or damage caused by either occurrence.

#### 3.1.3 Pipe Sizing

##### 3.1.3.1 Discharge Pipe

When the pump is located up to 15 metres (15m) from the pool, the recommended Class 9 minimum pipe size for the discharge side of the pump is ninety millimetres (90mm) for 0.75HP and fifty millimetres (50mm) for 1-2 HP.

**NOTE** All pipe sizes (Class 9) are able to withstand the pressures delivered by the pump, but not necessarily the flow. If the pipe is too small for the pump, or if the pump is elevated above water, the maximum litres per minute (LPM) may not be delivered. If this happens, the pump will develop an air pocket (cavitation) that will make noise, and the life of the pump may be shortened.

Figure 1. E3 Pump Controls and Modes

### 3.1.3.3 Installation Recommendations

1. If the pump is located below water level, isolation valves must be installed on both sides of the pump to prevent the back flow of pool water during any routine or required servicing.
2. FloPro Pumps come equipped with unions on both the suction and discharge ports. This feature simplifies installation and service and eliminates the possibility of leaks at threaded adapters.
3. The piping must be well supported and not forced together where it will experience constant stress.
4. Always use properly sized valves. Zodiac Diverter Valves and Ball Valves typically have the best flow capabilities.
5. Use the fewest fittings possible. Each additional fitting has the effect of moving the equipment farther away from the water.

**NOTE** If more than ten (10) suction fittings are needed, the pipe size must be increased.

## 3.2 Electrical Installation

### ⚠ WARNING

Always disconnect the power source before working on a motor or its connected load.

### ⚠ WARNING

Make sure that the control switch, time clock, or control system is installed in an accessible location, so that in the event of an equipment failure or a loose plumbing fitting, the equipment can be turned off. This location must not be in the same area as the pool pump, filter, and other equipment.

## 3.3 Conduct Pressure Testing

### ⚠ WARNING

When pressure testing a system with water, air is often trapped in the system during the filling process. This air will compress when the system is pressurized. Should the system fail, this trapped air can propel debris at a high speed and cause injury. Every effort to remove trapped air must be taken, including opening the bleed valve on the filter and loosening the pump basket lid while filling the pump.

### ⚠ WARNING

Trapped air in the system can cause the filter lid to be blown off, which can result in death, serious injury, or property damage. Be sure all air is properly purged out of the system before operating. **DO NOT USE COMPRESSED AIR TO PRESSURE TEST OR CHECK FOR LEAKS.**

### ⚠ WARNING

Do not pressure test above 35 PSI. Pressure testing must be done by a trained pool professional. Circulation equipment that is not tested properly might fail, which could result in severe injury or property damage.

### ⚠ WARNING

When pressure testing the system with water, it is very important to make sure that the pump basket lid is completely secure.

1. Fill the system with water, using care to eliminate trapped air.
2. Pressurize the system with water to no more than **35 PSI**.
3. Close the valve to trap pressurized water in the system.
4. Observe the system for leaks and/or pressure decay.

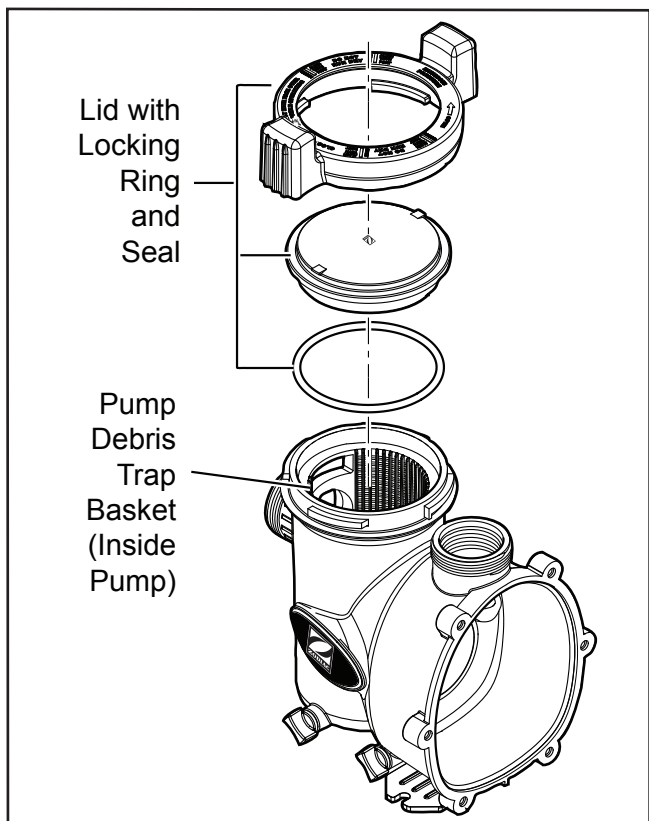

Figure 2. Exploded View of Pump



## Section 4. Operation

### 4.1 Start-up

#### CAUTION

Never run the pump without water. Running the pump “dry” for any length of time can cause severe damage to both the pump and motor and will void the warranty.

If this is a new pool installation, make sure all piping is clear of construction debris and has been properly pressure tested. The filter should be checked for proper installation, verifying that all connections and clamps are secure according to the manufacturer’s recommendations.

#### WARNING

To avoid risk of property damage, severe personal injury or death, verify that all power is turned off before starting this procedure.

1. Release all pressure from the system and open the filter pressure release valve.
2. Depending on the location of the pump, do one of the following:
  - If the pump is located below the water level of the pool, open the filter pressure release valve to prime the pump with water.
  - If the pump is located above the water level of the pool, remove the lid and fill the basket with water before starting the pump.
3. Prior to replacing the lid, check for debris around the lid o-ring seat. Debris around the lid o-ring seat will cause air to leak into the system and will make it difficult to prime the pump.
4. Hand-tighten the lid to make an air tight seal. Do not use any tools to tighten the lid: hand-tighten only. Make sure all valves are open and the unions are tight.
5. Restore power to the pump.
6. Once all the air has left the filter, close the pressure release valve.
7. The pump should prime. The time it takes to prime will depend on the elevation and length of pipe used on the suction supply pipe. See Section 3.1.3.3, Installation Recommendations, for proper elevation and pipe size.
8. If the pump does not prime and all the instructions to this point have been followed, check for a suction leak. If there is no leak, repeat Steps 2 through 7.
9. For technical assistance, call Zodiac Technical Support at 1.800.688.152.

### 4.2 Operational Controls

#### IMPORTANT

Due to an undervoltage protection placed in the software to protect the internal electronics, there may be an error during motor startup. If this situation occurs, simply let the motor sit without power for approximately 3-5 minutes to allow the capacitors to completely drain before restarting the motor.

#### NOTE

- If power is removed, motor will return to the last speed selected when power is restored.
- Motor will remember ON/OFF states.
- If there is a fault, Error LED will blink. See Section 6 more information on fault codes.

#### Normal Operation Mode

On start up, the LED for the selected speed will flash for approximately 1 minute as the pump goes through a priming cycle. When the cycle is complete, the LED for the selected speed will be steadily lit.

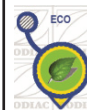

- For LOW speed, the LED will flash when selected until the priming cycle is complete. Once complete, the LED will be steadily lit.



- For MEDIUM speed, the LED will flash when selected until the priming cycle is complete. Once complete, the LED will be steadily lit.



- For HIGH speed, the LED will flash when selected until the priming cycle is complete. Once complete, the LED will be steadily lit.



- To turn OFF (LED will flash when selected)

Figure 3. Normal Operation Mode Controls

### Adjustable Speed Mode

- Press and hold the chosen speed button to be adjusted for approximately 3-5 seconds (until LED begins to flash) to switch to Adjustable Speed Mode.

Press Button:



- to decrease speed by 50 rpm increments with 1000 rpm as the minimum limit.



- to save current speed setting and return to normal operation mode. **Note:** Must hold for 10 seconds to save required speed setting).



- Each press will increase increase ECO and CLEAN speed by 50 RPM. HIGH speed is top speed of 2850 rpm, and can only be adjusted by 50 rpm if already adjusted.



- will cancel change and revert back to original speed, returning to normal operation mode.

Figure 4. Adjustable Speed Mode Operations

## Section 5. Service and Maintenance

### 5.1 Routine Maintenance

#### **⚠ WARNING**

To avoid risk of property damage, severe personal injury or death, verify that all power is turned off before starting this procedure.

Inspect the pump debris tray basket for debris by looking through the clear pump lid. Remove any debris, because as debris accumulates, it will begin to block the flow of water through the pump. Keep the basket clean to improve the performance of the pump.

1. Turn off the power to the pump. If the pump is located below the water level, close the isolation valves on the suction and discharge sides of the pump to prevent backflow of water.
2. Turn the lid's locking ring counter-clockwise until 'START' aligns with the ports. Carefully remove the lid. (A tool may be used for leverage.)

#### **CAUTION**

A misaligned basket will cause the lid to be improperly seated, allowing an air leak, which could result in pump damage.

3. Lift the basket out of the pump.
4. Dispose of the debris and thoroughly clean the basket, making sure all the holes are open. Using a garden hose, spray the basket from the outside to help clear the holes. Remove any remaining debris by hand.
5. Replace the basket in the pump by aligning the opening with the suction pipe. If aligned properly, the basket will drop easily into place. **Do not force it into place.**
6. Remove the lid seal and remove debris around the lid seal seat, as this can allow air to leak into the system. Clean the lid seal and place it on the lid.
7. Replace the lid with locking ring. **Hand-tighten** the lid to make an air-tight seal. Do not use any tools to tighten the lid: **hand-tighten only.**
8. Verify that all valves have been returned to the proper position for normal operation.
9. Open the pressure release valve on the filter, and make sure it is clean and ready for operation.
10. Turn on the power to the pump. Once all the air has been evacuated from the filter, close the pressure release valve.

Zodiac Group Australia Pty Ltd strongly recommends that you call a qualified service technician to perform any repairs on the filter/pump system. To locate a qualified technician, visit [www.zodiac.com.au](http://www.zodiac.com.au) and click on "Pool Maintenance - Zodiac Product Support".



## Section 6. Troubleshooting and Repair

Zodiac Group Australia Pty Ltd strongly recommends that you call a qualified service technician to perform any repairs on the filter/pump system. To locate a qualified technician, visit [www.zodiac.com.au](http://www.zodiac.com.au) and click on “Pool Maintenance - Zodiac Product Support”.

### 6.1 Troubleshooting

Symptom	Possible Cause/Solution
The cleaning/circulating system is not operating correctly.	<p>Verify that skimmer baskets, pump basket and other screens are clean. Clean as necessary.</p> <p>Check filter and clean as necessary.</p> <p>Check valve positions. Adjust as necessary.</p> <p><b>NOTE</b> Multiple pieces of equipment operating at one time (for example, waterfalls, spa jets, and surface returns) will affect the proper operation of the cleaning system.</p> <p>Check the cleaning system manual to ensure that the system is adjusted according to the manufacturer's recommendations.</p>
Bubbles are present in the pump basket.	<p>Air is in the system. Check the pool or spa water level to ensure that it is at the proper level and air is not being drawn into the suction piping. If the water is at the normal level, turn off the pump. Turn the lid's locking ring counter-clockwise until 'START' aligns with the ports. Remove the lid and check for debris around the lid seal seat OR improper installation of the lid seal, as either condition will allow air to leak into the system. Clean the lid seal and replace it on the lid. Replace the lid on the pump housing. Align 'START' with the ports and turn the locking ring clockwise until 'LOCKED' aligns with the ports. <b>Hand-tighten</b> the lid to make an air-tight seal. <b>Do not use any tools to tighten the lid.</b> Turn the pump back on.</p>
Air leaks are still present.	<p>Check the suction side piping union. While the pump is running, try to tighten the union. If this does not stop the air leak, turn off the pump. Loosen both unions and slide the pump out of the way. Remove, clean, and re-install both union o-rings.</p> <p>Reposition the pump next to the piping and secure the union nuts to the pump. With clean union o-rings, hand-tightening of the unions should create a seal. If the unions still do not seal, gently tighten with a large pair of tongue-and-groove pliers.</p> <p><b>Do not over-tighten.</b></p>
There is no air in the system, but the pressure is still low.	<p>It is possible that debris is caught in the pump impeller. The pump impeller moves the water, and the vanes in the impeller can become blocked with debris. See <i>Section 6.2, Service Technician Maintenance, 6.2.1, Blocked Impeller</i>, in this manual for more information.</p>
There is no debris blocking the impeller <b>and</b> the pressure is still low.	<p>The pump impeller and diffuser are showing signs of normal wear. Have a qualified service technician check the impeller and diffuser and replace as necessary.</p> <p>If the pump is part of a relatively new installation, it could be an electrical problem. Contact a qualified service technician. Have the technician check for loose electrical connections and check the voltage at the pump motor while it is in operation. The voltage must be within 10% of the motor's data plate rating. If the voltage is not within 10%, contact a qualified electrician and/or the local power service provider.</p> <p>Pump seal is leaking air. Have a qualified service technician replace the seal.</p>
The pump is leaking water between the motor and pump body.	<p>This is caused by a damaged or failed mechanical seal. Replace the seal. See <i>Section 6.2, Service Technician Maintenance, 6.2.3, Mechanical Seal Replacement</i>, in this manual.</p>
The pump gets hot and shuts off periodically.	<p>Make sure that there is adequate room around the motor to circulate air and keep the motor cool. Have a qualified electrician check for loose connections and check the voltage at the pump motor while it is in operation. The voltage must be within 10% of the motor's data plate rating. If the voltage is not within 10%, contact a qualified electrician and/or the local power service provider.</p>

## 6.2 Fault Codes

Blinks	Fault	Cause
1	Micro Controller failure	Micro controller is continually rebooting.
2	Mains under voltage	The mains voltage has dropped below 180 volts AC running.  Note: If this fault is active, the controller will reboot after voltage rises above 209 volts AC for at least 6 seconds.
3	Temperature	Over temperature (100° C) Under temperature (-20° C)
4	Over-current trip	Over current protection has been tripped.
5	Mains over voltage	Main voltage has risen above 269 volts AC.
6	Output shaft seized	Motor failed to start. Motor was stopped.
7	Self check	One or more of the self tests failed either at startup or during operation.
8	Motor fault	One or more of the phases has become disconnected.
10	Other fault	Any fault not covered by other codes.  Note: Presently, no faults should trigger this indicator.
none	EEPROM load failure	Checksum failed while loading EEPROM to memory.

## 6.3 Service Technician Maintenance

### WARNING

This pump must be serviced by a professional service technician qualified in pool/spa installation. The following procedures must be followed exactly. Improper installation and/or operation can create dangerous electrical hazards, which can cause high voltages to run through the electrical system. This can cause property damage, serious personal injury, and/or death. Improper installation and/or operation will void the warranty.

### 6.3.1 Blocked Impeller

### WARNING

Before servicing the pump, switch off the circuit breakers at the power source. Severe personal injury or death may occur if the pump starts while your hand is inside the pump.

1. Turn off the pump. Switch off the circuit breaker to the pump motor.
2. Remove the lid and basket.
3. Look inside the pump for debris. Remove any debris found inside.
4. Replace the basket and lid.
5. Switch on the circuit breaker to the pump motor.
6. Turn on the pump, and see if the problem is solved.
7. If the impeller is still blocked with debris and it is not possible to remove the debris using Steps 2 through 4, the pump will need to be disassembled in order to access the inlet and outlet of the impeller.

### 6.3.2 Impeller Removal and Replacement

### WARNING

Before servicing the pump, switch off the circuit breakers at the power source. Severe personal injury or death may occur if the pump starts while your hand is inside the pump.

1. Turn off the pump. Switch off the circuit breaker to the pump motor. If you are not replacing the motor, do not disconnect the electrical wiring.
- NOTE** If you are replacing the motor, Zodiac strongly recommends that a qualified service technician or electrician properly disconnect the electrical wiring at the pump motor.
2. Turn off any valves to prevent pool water from reaching the pump. Drain the water from the pump by loosening the unions or removing the drain plugs.
  3. Using a 9/16" wrench, loosen the bolts connecting the pump body to the motor backplate. See Figure 13.
  4. Pull the motor and backplate out of the pump body. Remove the pump body o-ring. The impeller is connected to the motor shaft.
  5. Using a No. 1 Phillips screwdriver, remove the two (2) screws holding the diffuser. (The diffuser is the cover over the impeller.) Then remove the diffuser (See Figure 14).
  6. Access the inlet and outlet of the impeller and remove any debris.

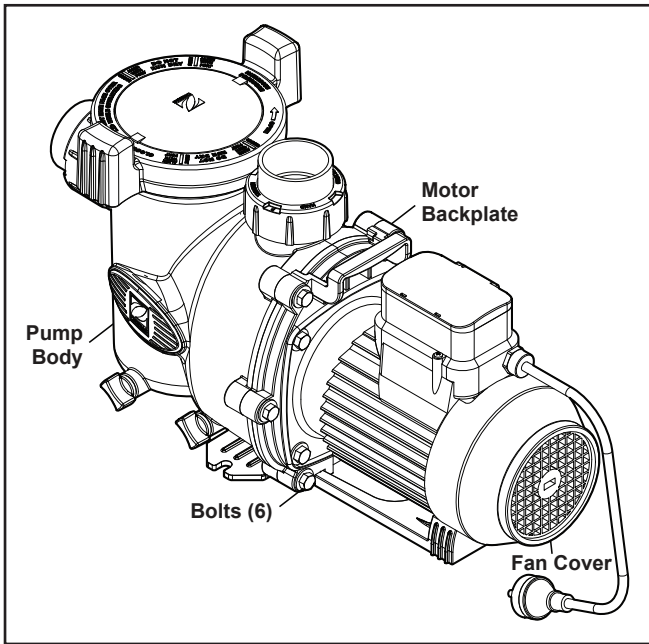

Figure 13. Remove the Pump Housing

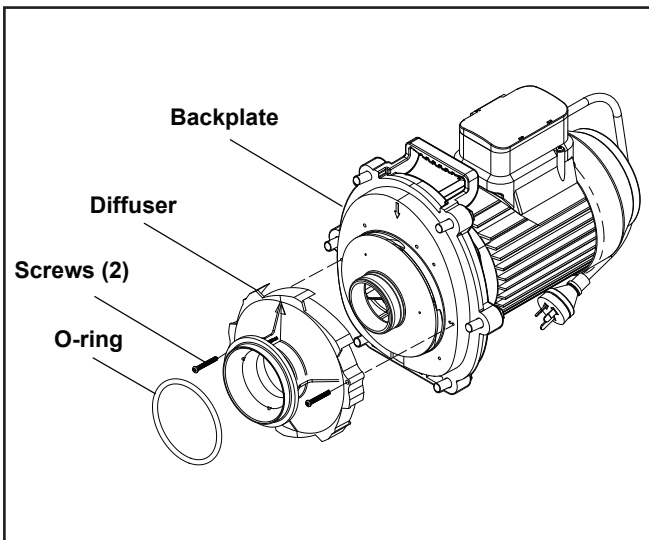

Figure 14. Remove the Diffuser

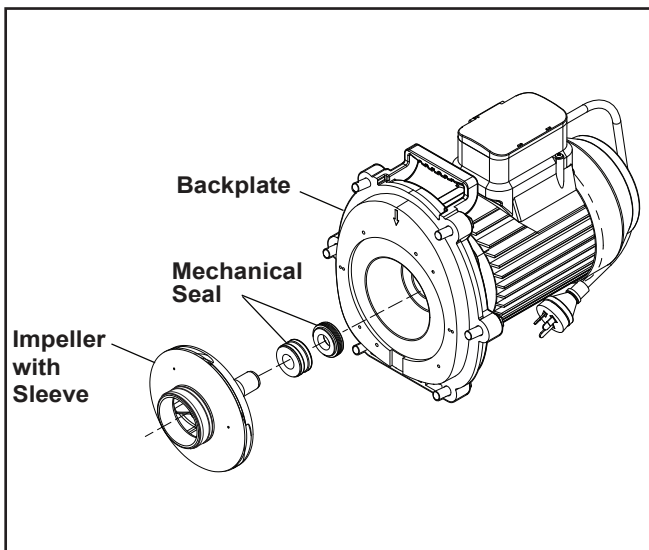

Figure 15. Remove the Impeller

7. Hold the motor shaft with a 1/4" hex allen wrench while unscrewing the impeller from the motor shaft with your hand. Turn the impeller counter-clockwise to unscrew it. See Figure 15.
8. Inspect the impeller and diffuser for signs of rubbing and/or damage.

### 6.3.2.1 Impeller Reassembly

1. Press the new carbon face seal half (see Figures 16 and 17) on the impeller shaft using a twisting motion. Make sure the carbon surface is facing toward the ceramic ring in the backplate.

## CAUTION

**Very Important!** To prevent damage to the seal, grasp the lower portion of the seal (opposite the carbon face) when installing it.

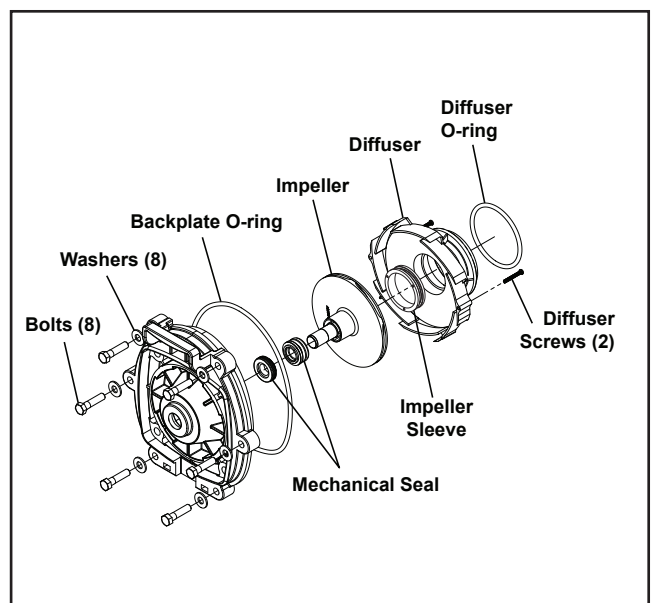

Figure 16. Diffuser and Impeller Exploded View

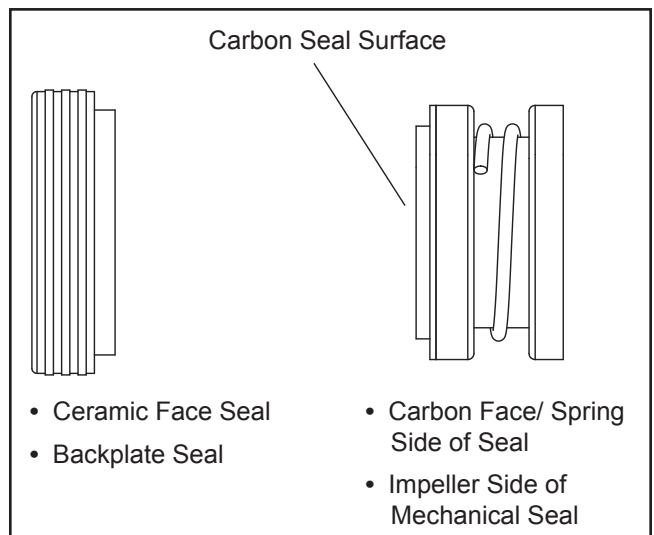
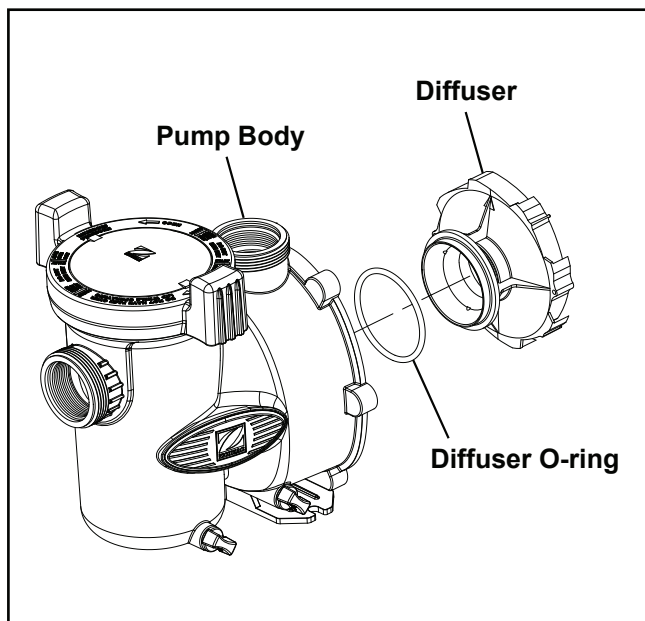

Figure 17. Mechanical Seal

**NOTE** To assist assembly, use only water or soapy water as a lubricant. Any other lubricant will destroy the seal after a short period of time.

**NOTE** Be sure to keep the seal and mating parts clean.

2. While holding the motor shaft with a large flat-bladed screwdriver, thread the impeller onto the motor shaft. Hand-tighten the impeller until it is secure. **Do not overtighten.**
3. Install the impeller sleeve on the impeller.
4. Place the diffuser over the impeller, using care to insert alignment pins into the correct holes. The molded-in arrow must point toward the handle of the backplate.
5. Replace the two (2) small Phillips-head screws. Tighten the screws to draw the diffuser against the motor backplate.
6. To help prevent an airleak into the system, make sure the diffuser o-ring, o-ring groove, and o-ring seal area are clean and free of debris. If you removed the diffuser o-ring, make sure you install it into the groove you removed it from. (See Figure 18.) If grease is used to retain the o-ring, it **must** be silicone based. **Do not use petroleum-based grease.** It will destroy the o-ring.



**Figure 18. Pump Body and Diffuser Exploded View**

7. Slide the diffuser into the mating hole in the pump body. While supporting the motor, start two (2) screws on opposite sides. (This will hold the motor in position while you start the other six (6) screws.)

8. Tighten the screws lightly in a crossing “X” pattern using a 9/16” wrench. Start with the inner (middle) four (4), then the outer (top and bottom) four (4) to draw the backplate to the body in an even manner. Once all the screws are snug, torque in the same order to 13 Nm.
9. If the pump is located above the water level of the pool, remove the lid and fill the basket with water before starting the pump.
10. To help prevent an air leak into the system, remove any debris around the lid seal seat.
11. **Hand-tighten** the lid to make an air tight seal. **Do not use any tools to tighten the lid.**
12. Open the pressure release valve on the filter and make sure it is clean and ready for operation.
13. Switch on the circuit breaker to the pump motor.
14. Turn on the pump and check the system for normal operation.
15. Once all the air has left the filter, close the pressure release valve.

### 6.3.3 Mechanical Seal Replacement

**NOTE** This is a two-part replacement process. **The mechanical seal must be replaced as a set.**

**NOTE** Refer to Figure 19 for an illustration of the location of the mechanical seal and impeller.

## CAUTION

Do not damage the ceramic or carbon surfaces of the seals. If the surfaces are damaged, leaks will occur.

1. To access the mechanical seal, see Section 6.3.2, Impeller Removal and Replacement.

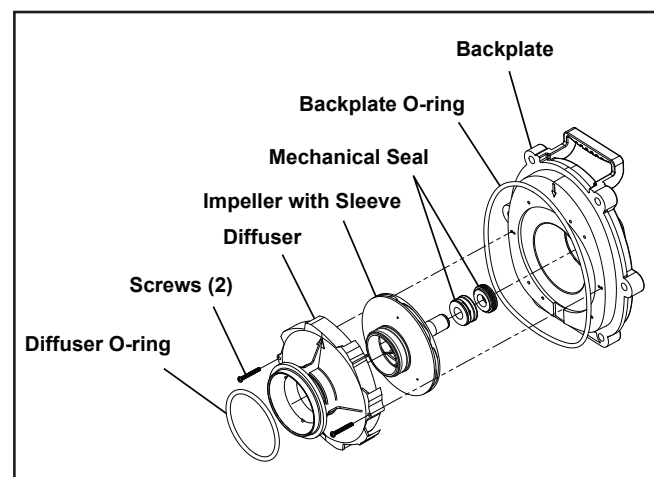

**Figure 19. Backplate, Impeller, Diffuser, Mechanical Seal Exploded View**



2. Remove the carbon face seal half from the impeller shaft (See Figure 15). This is a spring-loaded seal. Grasp the portion of the seal closest to the impeller body and pull the seal off, using a twisting motion.
3. Remove the motor from the backplate, following the steps in Section 6.3.4, Motor Replacement.
4. Place the backplate o-ring side down and force the ceramic seal out using a screwdriver or drift.
5. Turn the backplate o-ring side up and insert the new ceramic seal side into the backplate. Use great care to press the seal in squarely with your fingers. The ceramic is easily damaged and must be pressed in using only your fingers or soft tools. Do not use any lubricant other than water or soapy water.
6. Install the backplate by following the relevant steps in Section 6.3.2.1, Impeller Reassembly.
7. Install the motor by following the steps in Section 6.3.4, Motor Replacement.
4. Place the motor on the backplate so that the opening in the motor faces the bottom of the backplate. The electronics controller on the motor should be at the 12 o'clock position.
5. Replace the four (4) bolts and washers holding the backplate to the motor and torque to 20 Nm. See Figure 20.
6. To reassemble the backplate assembly to the housing, see Section 6.3.2.1, Impeller Reassembly.
7. If the pump is located above the water level of the pool, remove the lid and fill the basket with water before starting the pump.
8. To help prevent an air leak into the system, remove any debris around the lid seal seat.
9. **Hand-tighten** the lid to make an air tight seal. **Do not use any tools to tighten the lid.**
10. Open the pressure release valve on the filter and make sure it is clean and ready for operation.
11. Have a qualified service technician or electrician properly connect the electrical wiring at the pump motor.
12. Turn on the electrical power to the pump motor using your controller and check the system for normal operation.
13. Once all the air has left the filter, close the pressure relief valve.

### 6.3.4 Motor Replacement

#### **⚠ WARNING**

To ensure continued safety and reliable operation, Zodiac® requires that you replace the motor with a motor listed in the spares list that has the identical HP rating and service factor (Zodiac approved only).

1. Have a qualified service technician or electrician properly disconnect the electrical wiring at the pump motor.

#### **⚠ WARNING**

#### **ELECTRICAL SHOCK HAZARD**

Turn off power to the FloPro pump electrical circuit before starting the procedure. Wait five (5) minutes after power is disconnected before opening motor. Failure to comply may cause a shock hazard, resulting in severe personal injury or death.

2. To detach the pump housing from the motor, see Section 6.3.2, Impeller Removal and Replacement.
3. Note the alignment of the backplate to the motor, as shown in Figure 20. Place the backplate motor assembly o-ring side down, unscrew the four 9/16" screws, and remove the motor.

**NOTE** Zodiac recommends that the mechanical seals be replaced at the same time the motor is replaced. See Section 6.3.3, Mechanical Seal Replacement, for details.

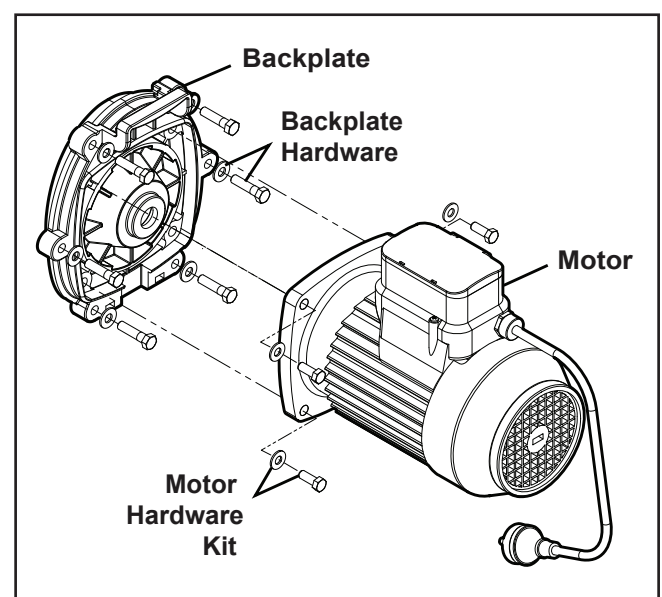

Figure 20. Backplate Assembly

## Section 7. Product Specifications and Technical Data

### 7.1 Replacement Parts List

To order or purchase parts for Zodiac® pumps, contact your nearest Zodiac dealer. If the Zodiac dealer cannot supply you with what you need, contact Zodiac technical support at 1.800.688.152, or send an e-mail message to [apac.aftersales@zodiac.com](mailto:apac.aftersales@zodiac.com).

Key No.	Description	Order Part No.
1	E3, MOTOR & HARDWARE, WFHP 1.0HP	R0755900
2	BACKPLATE, WFHP	R0734900
3	IMPELLER, WFHP, 1.0HP	R0735100
4	DIFFUSER, WFHP	R0735400
5	MECHANICAL SEAL, CARBON & CERAMIC (1 SET)	R0735500
6	E3,PUMP BODY, WFHP	R0755000
7	FOOT, MOTOR, FHP SERIES, WFHPM (AUSTRALIA)	A0133001
8	LID W/LOCKING RING, WFHP (LID W/LOCKING RING & LID O-RING)	R0736500
9	PUMP DEBRIS FILTER BASKET, WFHP	R0736600
10	DRAIN PLUG W/O-RING, WFHP	R0735700
11	TAIL PIECE, O-RING & UNION NUT	R0735800
12	LID O-RING, WFHP	R0736700
13	BACKPLATE O-RING, WFHP	S0137300
14	O-RING, EPDM, 70 DURO A568 2-340	S0119000
15	DIFFUSER/IMPELLER HARDWARE	R0735900
16	BACKPLATE HARDWARE, WFHP	R0736000
17	MOTOR HARDWARE KIT	R0736100

### 7.2 General Specifications

Supply Rated	240V AC, 50 hz, 6.5 Amps
Installed Load	1,000 W Max.
Max Head	19.1M
IP Rating	IPX5



### 7.3 Exploded View

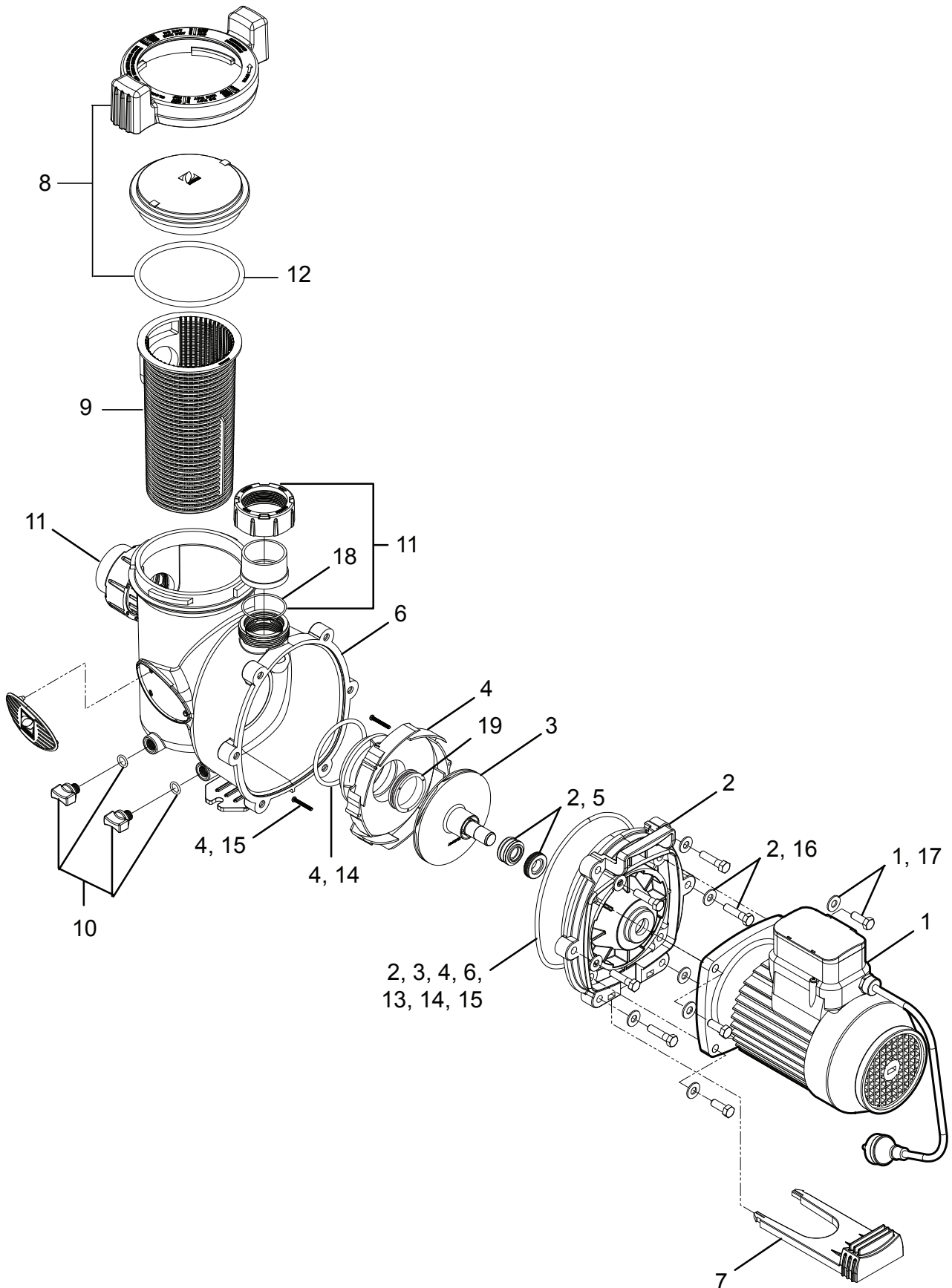

**Zodiac Group Australia.**

219 Woodpark Road  
Smithfield, NSW AU 2164  
1.800.688.552 | [www.zodiac.com.au](http://www.zodiac.com.au)

©2018 Zodiac Pool Systems LLC ZODIAC® is a registered trademark of Zodiac International, S.A.S.U., used under license. All trademarks referenced herein are the property of their respective owners.

H0394700 Rev D

