



ZODIAC

Installation and Operation Manual

FloPro Series Pumps

Model FHPM

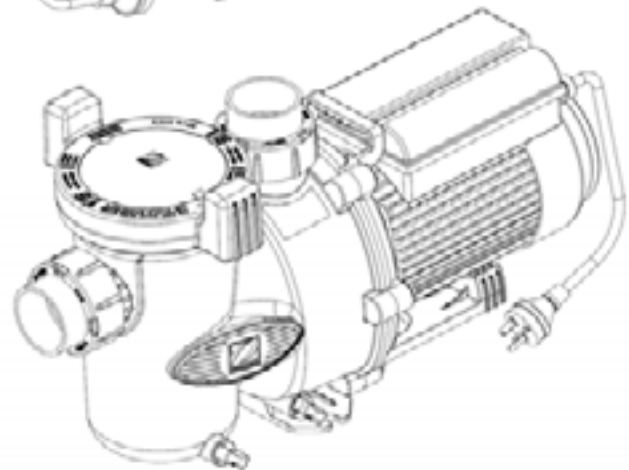
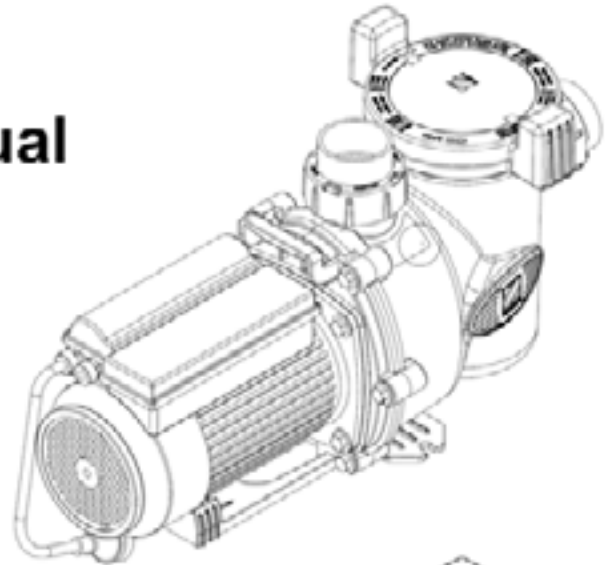

WARNING

FOR YOUR SAFETY: This product must be installed and serviced by a professional service technician, qualified in pool/spa installation. The procedures in this manual must be followed exactly. Improper installation and/or operation can create dangerous electrical hazards, which can cause high voltages to run through the electrical system, possibly causing death, serious injury or property damage. Improper installation and/or operation will void the warranty.



ATTENTION INSTALLER: This manual contains important information about the installation, operation and safe use of this product. This information should be given to the owner/operator of this equipment.



Table of Contents

Section 1. Important Safety Instructions	4	Section 6. Troubleshooting and Repair	10
1.1 Safety Instructions	4	6.1 Troubleshooting	10
1.2 Pool Pump Suction Entrapment Prevention Guidelines	6	6.2 Service Technician Maintenance	11
Section 2. General Description.....	7	6.2.1 Blocked Impeller.....	11
2.1 Introduction.....	7	6.2.2 Impeller Removal.....	11
2.2 Description.....	7	6.2.3 Impeller Replacement.....	12
Section 3. Installation.....	7	6.2.4 Mechanical Seal Replacement	13
3.1 Plumbing.....	7	6.2.5 Motor Replacement.....	14
3.1.1 Preparation.....	7	Section 7. Product Specifications and Technical Data.....	15
3.1.2 Pump Location.....	7	7.1 Replacement Parts List	15
3.1.3 Pipe Sizing	7	7.2 Exploded View	16
3.2 Electrical Installation	8	7.3 Performance Curves.....	17
3.2.1 Bonding and Grounding.....	8	7.4 Physical and Operational Specifications.....	18
3.3 Pressure Testing	8		
Section 4. Operation.....	9		
4.1 Start-up.....	9		
Section 5. Service and Maintenance	9		
5.1 Routine Maintenance	9		

EQUIPMENT INFORMATION RECORD

DATE OF INSTALLATION _____

INSTALLER INFORMATION _____

INITIAL PRESSURE GAUGE READING (WITH CLEAN FILTER) _____

PUMP MODEL _____ HORSEPOWER _____

NOTES: _____



Section 1. Important Safety Instructions

READ AND FOLLOW ALL INSTRUCTIONS

1.1 Safety Instructions

All electrical work must be performed by a licensed electrician and conform to all national, state, and local codes. When installing and using this electrical equipment, basic safety precautions should always be followed, including the following:

WARNING

RISK OF SUCTION ENTRAPMENT HAZARD, WHICH, IF NOT AVOIDED, CAN RESULT IN SERIOUS INJURY AND/OR DEATH. Do not block pump suction, as this can cause severe injury and/or death. Do not use this pump for wading pools, shallow pools, or spas containing bottom drains, unless the pump is connected to at least two (2) functioning suction outlets. Drain covers must be certified to the latest published version of AS 1926.3.

WARNING

To reduce the risk of injury, do not permit children to use this product.

WARNING

To reduce the risk of property damage and/or injury, do not attempt to change the backwash (multiport, slide, or full flow) valve position with the pump running.

WARNING

Incorrectly installed equipment may fail, causing severe injury and/or property damage.

WARNING

The pump is for fixed installations only and to be used in conjunction with swimming pool equipment. (e.g. filters).

The pump is to be installed in accordance with the relevant requirements of the Australian wiring rules AS/NZS 3000.

Also refer to the installation instructions relating to the swimming pool equipment for which the pump will be an integral part.

The pump is to be supplied through a residual current device (RCD) with a rated residual operating current of 30mA.

If the supply cord is damaged it must be replaced by the manufacturer or its service agent or similarly qualified person in order to avoid a hazard.

**⚠ WARNING**

To minimize the risk of severe injury or death, the filter and/or pump should not be subjected to the piping system pressurization test.

Local codes may require the pool piping system to be subjected to a pressure test. These requirements are generally not intended to apply to the pool equipment, such as filters or pumps.

Zodiac pool equipment is pressure tested at the factory.

However, if the WARNING cannot be followed and pressure testing of the piping system must include the filter and/or pump, **BE SURE TO COMPLY WITH THE FOLLOWING SAFETY INSTRUCTIONS:**

- Check all clamps, bolts, lids, lock rings, and system accessories to make sure they are properly installed and secured before testing.
- **RELEASE ALL AIR** in the system before testing.
- Water pressure for test must **NOT EXCEED 35 PSI (245 kPa)**.
- Water temperature for test must **NOT EXCEED 100°F (38°C)**.
- Limit test to 24 hours. After test, visually check the system to make sure it is ready for operation.

Notice: These parameters apply to Zodiac equipment only. For non-Zodiac equipment, consult the equipment manufacturer.

⚠ WARNING

Chemical spills and fumes can weaken pool/spa equipment. Corrosion can cause filters and other equipment to fail, resulting in severe personal injury or property damage. Do not store pool chemicals near your equipment.

CAUTION

Do not start pump dry! Running the pump dry for any length of time will cause severe damage and will void the warranty.

CAUTION

This pump is for use with permanently installed pools and may also be used with hot tubs and spas, if so marked. Do not use with storable pools. A permanently installed pool is constructed in or on the ground or in a building such that it cannot be readily disassembled for storage. A storable pool is constructed so that it may be readily disassembled for storage and reassembled to its original integrity.

SAVE THESE INSTRUCTIONS



1.2 Pool Pump Suction Entrapment Prevention Guidelines



WARNING

SUCTION HAZARD. Can cause serious injury or death. Do not use this pump for wading pools, shallow pools, or spas containing bottom drains, unless the pump is connected to at least two (2) functioning suction outlets and as per AS1926.3.

WARNING

Pump suction is hazardous and can trap and drown or disembowel bathers. Do not use or operate swimming pools, spas, or hot tubs if a suction outlet cover is missing, broken, or loose. The following guidelines provide information for pump installation that minimizes the risk of injury to users of pools and spas. Refer to Australian Standard 1926.3 for further information.

WARNING

The pump is not intended for use by young children or infirm persons unless they have been adequately supervised by a responsible person to ensure that they can use the pump safely.

Young children should be supervised to ensure that they do not play with the pump.



Section 2. General Description

2.1 Introduction

This manual contains information for the proper installation, operation, and maintenance of Zodiac FloPro (FHP) Series Pumps, Model FHPM. Procedures in this manual must be followed exactly. To obtain additional copies of this manual, contact Zodiac Customer Service at 1800 688 552. For address information, see the back cover of this manual.

2.2 Description

Zodiac FloPro Pumps are designed to meet the needs of today's more hydraulically demanding pool equipment. The pump housing, backplate, diffuser, impeller, and hair-and-lint pot (pump debris filter basket) are all made from high quality thermoplastic materials. These materials were chosen for their strength and corrosion resistance.

The pump is driven by an electric motor directly attached to the pump impeller. As the electric motor turns, it causes the impeller to turn, which forces water to flow through the pump. The water flows through the pump inlet and then into the filter basket. The basket assembly pre-strains/traps large particles. The water then enters the center of the pump housing, flows through the impeller into the diffuser, and then flows out the pump discharge port.

Section 3. Installation

3.1 Plumbing

3.1.1 Preparation

1. Upon receipt of the pump, check the carton for damage. Open the carton and check the pump for concealed damage, such as cracks, dents, or a bent base. If you find damage, contact the shipper or the distributor where the pump was purchased.
2. Inspect the contents of the carton and verify that all parts are included. See *Section 7.1, Replacement Parts List*.

3.1.2 Pump Location

1. Zodiac Group Australia Pty Ltd recommends installing the pump within 300mm above water level. The pump should not be elevated more than a metre above the water level of the pool. A check valve is recommended on the suction line to the pump.

NOTE Better self-priming will be achieved if the pump is installed as close as possible to the water level of the pool.

2. If the pump is located below water level, isolation valves **must** be installed on both the suction and return lines to prevent the back flow of pool water during any routine or required servicing.
3. Zodiac Pool Systems, Inc. recommends that the pump and other circulation equipment be located more than 1.5 metres from the water. Choose a location that will minimize turns in the piping.
4. The pump must be placed on a solid foundation that will not vibrate. To further reduce the possibility of vibration noise, bolt the pump to the foundation, or place it on a rubber mat.

NOTE Zodiac Group Australia Pty Ltd recommends bolting the pump directly to the foundation.

5. The pump foundation must have adequate drainage to prevent the motor from getting wet. Protect the pump from the rain and sun.
6. Proper ventilation is required for the pump to operate normally. All motors generate heat that must be removed by providing proper ventilation.
7. Provide access for future service by leaving a clear area around the pump. Allow plenty of space above the pump to remove the lid and basket for cleaning.
8. If the equipment is under cover, provide adequate lighting.

3.1.3 Pipe Sizing

3.1.3.1 Suction Pipe

When the pump is located up to 15 metres from the pool, the recommended Class 9 minimum pipe size for the suction side of the pump is 40mm for .75 HP and 50mm for 1 to 2 HP.

3.1.3.2 Discharge Pipe

When the pump is located up to 15 metres from the pool, the recommended Class 9 minimum pipe size for the discharge side of the pump is 90mm for .75 HP and 50mm for 1 to 2 HP.

NOTE All pipe sizes (Class 9) are able to withstand the pressures the pump will deliver, but not necessarily the flow. If the pipe is too small for the pump, or if the pump is elevated above water, the maximum litres per minute (LPM) may not be delivered. If this happens, the pump will develop an air pocket (cavitation) that will make noise, and the life of the pump may be shortened.



3.1.3.3 Installation Recommendations

1. If the pump is located below water level, isolation valves *must* be installed on both sides of the pump to prevent the back flow of pool water during any routine or required servicing.
2. FHP Pumps come equipped with unions on both the suction and discharge ports. This feature simplifies installation and service, and it eliminates the possibility of leaks at threaded adapters.
3. The piping must be well supported and not forced together in places where constant stress will be experienced.
4. Always use properly sized valves. Zodiac Diverter Valves and Zodiac Ball Valves typically have the best flow capabilities.
5. Use the fewest fittings possible. Every additional fitting has the effect of moving the equipment farther away from the water.

NOTE If more than 10 suction fittings are needed, the pipe size must be increased.

3.2 Electrical Installation

3.2.1 Bonding and Grounding

1. Bond the motor using the provided external lug.

WARNING

To avoid the risk of property damage, severe personal injury, and/or death, always disconnect the power source before working on a motor or its connected load.

WARNING

To avoid the risk of property damage, severe personal injury, and/or death, make sure that the control switch or time clock is installed in an easily accessible location, so that in the event of an equipment failure or a loose plumbing fitting, the equipment can be easily turned off.

3.3 Pressure Testing

WARNING

When pressure testing a system with water, air is often trapped in the system during the filling process. This air will compress when the system is pressurized. Should the system fail, this trapped air can propel debris at a high speed and cause property damage, severe injury, or death. Every effort to remove trapped air must be taken, including opening the bleed valve on the filter and loosening the pump basket lid while filling the pump.

WARNING

Trapped air in system can cause the filter lid to be blown off, which can result in death, serious personal injury, or property damage. Be sure all air is properly out of system before operating. **DO NOT USE COMPRESSED AIR TO PRESSURE TEST OR CHECK FOR LEAKS.**

WARNING

Do not pressure test above 245 kpa. Pressure testing must be done by a trained pool professional. Circulation equipment that is not tested properly may fail. This could result in severe personal injury or property damage.

WARNING

When pressure testing the system with water, it is very important to make sure that the pump basket lid is completely secure.

1. Fill the system with water, being careful to eliminate trapped air.
2. Pressurize the system with water to no more than **245 kpa**.
3. Close the valve to trap pressurized water in the system.
4. Carefully observe the system for leaks and/or pressure decay.



Section 4. Operation

4.1 Start-up

CAUTION

Never run the pump without water. Running the pump "dry" for any length of time can cause severe damage to both the pump and motor and will void the warranty.

If this is a new pool installation, make sure all piping is clear of construction debris and has been properly pressure tested. Check the filter for proper installation, verifying that all connections and clamps are secure according to the manufacturer's recommendations.

⚠ WARNING

To avoid risk of property damage, severe personal injury, or death, verify that all power is turned off before starting this procedure.

1. Release all pressure from the system and open the filter pressure release valve.
2. Take one of the following actions:
 - If the pump is located below the water level of the pool, open the filter pressure release valve to prime the pump with water.
 - If the pump is located above the water level, remove the lid and fill the basket with water before starting the pump.
3. Prior to replacing the lid, check for debris around the lid o-ring seat. Debris around the lid o-ring seat will cause air to leak into the system, and make it difficult to prime the pump.
4. **Hand-tighten** the lid to make an air tight seal. **Do not use any tools to tighten the lid: hand-tighten only.** Ensure that the lid is secure. Make sure all valves are open and the unions are tight.
5. Restore power to the pump and then turn it on.
6. Once all the air has left the filter, close the filter pressure release valve.
7. The pump should prime. The time it takes to prime will depend on the elevation and length of pipe used on the suction supply pipe. See *Section 3.1.3.3, Installation Recommendations for proper elevation and pipe size.*
8. If the pump does not prime and all the instructions to this point have been followed, check for a suction leak. If there is no leak, repeat Steps 2 through 5.
9. For technical assistance, call Zodiac Technical Support at 1800 688 552.

Section 5. Service and Maintenance

5.1 Routine Maintenance

⚠ WARNING

To avoid the risk of property damage, severe personal injury, and/or death, turn off the pump before servicing the pump.

Inspect the pump basket for debris by looking through the clear pump lid. Remove any debris, because as debris accumulates, it will begin to block the flow of water through the pump. Keep the basket clean to improve the performance of the pump.

1. Turn off the power to the pump. If the pump is located below the water level, close the isolation valves on the suction and discharge sides of the pump to prevent backflow of water.
2. Turn the lid's locking ring counter-clockwise until 'START' aligns with the ports. Carefully remove the lid.

CAUTION

A misaligned basket will cause the lid to be improperly seated, allowing an air leak, which could result in pump damage.

3. Lift the basket out of the pump. Dispose of all debris and thoroughly clean the basket, making sure all the holes are open. Using a garden hose, spray the basket from the outside to help clear the holes. Remove any remaining debris by hand.
4. Replace the basket in the pump by aligning the open section of the basket with the inlet pipe. If aligned properly, the basket will drop easily into place. **Do not force it into place.**
5. Remove the lid o-ring and remove debris around the lid o-ring seat, as this will cause air leaks into the system. Clean the lid o-ring and replace it.
6. Replace the lid with locking ring on the pump housing. Align 'START' with the ports and turn the lid's locking ring clockwise until 'LOCKED' aligns with the ports. **Hand-tighten** the lid to make an air tight seal. **Do not use any tools to tighten the lid.**
7. Verify that all valves have been returned to the proper position for normal operation.
8. Open the pressure release valve on the filter, and make sure it is clean and ready for operation.
9. Turn on the power to the pump. Once all the air has been evacuated from the filter, close the filter pressure release valve.



Section 6. Troubleshooting and Repair

Zodiac Group Australia Pty Ltd strongly recommends that you call a qualified service technician to perform any repairs on the filter/pump system. To locate a qualified technician, check your local yellow pages or visit www.zodiac.com.au and click on "Product Support."

6.1 Troubleshooting

Symptom	Possible Problem/Solution
The cleaning/circulating system is not operating correctly.	<p>Verify that skimmer baskets, pump basket and other screens are clean. Clean as necessary.</p> <p>Check filter and clean as necessary.</p> <p>Check valve positions. Adjust as necessary.</p> <p>NOTE Multiple pieces of equipment operating at one time (for example, waterfalls, spa jets, and surface returns) may affect the cleaning system and prevent it from working properly.</p> <p>Check the cleaning system manual to ensure that the system is adjusted according to the manufacturer's recommendations.</p>
Bubbles present in the pump basket.	<p>Air in system. Check the pool or spa water level to ensure that it is at the proper level and that air is not being drawn into the suction piping. If the water is at the normal level, turn off the pump. Turn the lid's locking ring counter-clockwise until 'START' aligns with the ports. Carefully remove the lid and check for debris around the lid o-ring seat, as debris will cause air to leak into the system. Clean the lid o-ring and place on the lid. Replace the lid with locking ring on the pump housing. Align 'START' with the ports and turn the lid's locking ring clockwise until 'LOCKED' aligns with the ports. Hand-tighten the lid to make an air tight seal. Do not use any tools to tighten the lid. Turn the pump back on.</p>
Air leaks are still present.	<p>Check the suction side piping union. While the pump is running, try to tighten the union. If this does not stop the air leak, turn off the pump. Loosen both unions and slide the pump out of the way. Remove, clean and re-install both union o-rings.</p> <p>Reposition the pump next to the piping and secure the union nuts to the pump. With clean union o-rings, hand-tightening of the unions should create a seal. If the unions still do not seal, gently tighten with a large pair of tongue-and-groove pliers.</p> <p>Do not over-tighten.</p>
There is no air in the system, but the pressure is still low.	<p>It is possible that debris is caught in the pump impeller. The pump impeller moves the water, and the vanes in the impeller can become blocked with debris. See Section 6.2, <i>Service Technician Maintenance, 6.2.1, Blocked Impeller</i>, for more information.</p>
There is no debris blocking the impeller and the pressure is still low.	<p>The pump impeller and diffuser are showing signs of normal wear. Have a qualified service technician check the impeller and diffuser and replace as necessary.</p> <p>If the pump is part of a relatively new installation, it could be an electrical problem. Contact a qualified service technician. Have the technician check for loose electrical connections and check the voltage at the pump motor while it is in operation. The voltage must be within 10% of the motor's data plate rating. If the voltage is not within 10%, contact a qualified electrician and/or the local power service provider.</p> <p>The pump seal is leaking air. Have a qualified service technician replace the seal.</p>
The pump is leaking water between the motor and pump body.	<p>This is caused by a damaged or failed mechanical seal. Replace the seal. See Section 6.2, <i>Service Technician Maintenance, 6.2.4, Mechanical Seal Replacement</i>.</p>
The pump gets hot and shuts off periodically.	<p>Ensure that there is adequate room around the motor to circulate air and keep the motor cool. Have a qualified electrician check for loose connections and check the voltage at the pump motor while it is in operation. The voltage must be within 10% of the motor's data plate rating. If the voltage is not within 10%, contact a qualified electrician and/or the local power service provider.</p>

6.2 Service Technician Maintenance

WARNING

This pump must be serviced by a professional service technician, qualified in pool/spa installation. The following procedures must be followed exactly. Improper installation and/or operation can create dangerous electrical hazards, which can cause high voltages to run through the electrical system. This can cause property damage, serious injury, and/or death. Improper installation and/or operation will void the warranty.

6.2.1 Blocked Impeller

WARNING

Before servicing the pump, turn off the pump and switch off the circuit breaker to the pump motor. Severe personal injury, death, or property damage may occur if the pump starts while your hand is inside the pump.

1. Turn off the pump. Switch off the circuit breaker to the pump motor.
2. Remove the lid and basket.
3. Look inside the pump for any debris. Remove any debris found inside.
4. Replace the basket and lid.
5. Switch on the circuit breaker to the pump motor.
6. Turn on the pump, and see if the problem is solved.
7. If the impeller is still blocked with debris and it is not possible to remove the debris using Steps 2 through 4, the pump will need to be disassembled in order to access the inlet and outlet of the impeller.

6.2.2 Impeller Removal

WARNING

Before servicing the pump, turn off the pump and switch off the circuit breaker to the pump motor. Severe personal injury, death, or property damage may occur if the pump starts while your hand is inside the pump.

1. Turn off the pump. Switch off the circuit breaker to the pump motor. If you are not replacing the motor, do not disconnect the electrical wiring.

NOTE If you are replacing the motor, Zodiac Group Australia Pty Ltd strongly recommends that a qualified service technician or electrician properly disconnect the electrical wiring at the pump motor.

2. Turn off any valves to prevent pool water from reaching the pump. Drain the water from the pump by loosening the unions or removing the drain plugs.
3. Using a strap wrench, loosen the bolts connecting the pump body to the motor backplate. See Figure 7.

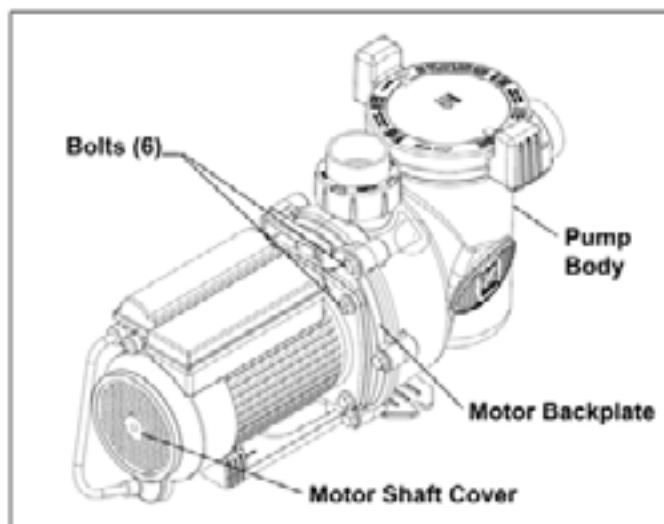

Figure 7. Remove the Pump Housing

4. Pull the motor and backplate out of the pump body. Remove the pump body o-ring. The impeller is connected to the motor shaft.
5. Using a No. 1 Phillips screwdriver, remove the two (2) screws holding the diffuser. (The diffuser is the cover over the impeller). Then remove the diffuser. (See Figure 8.)

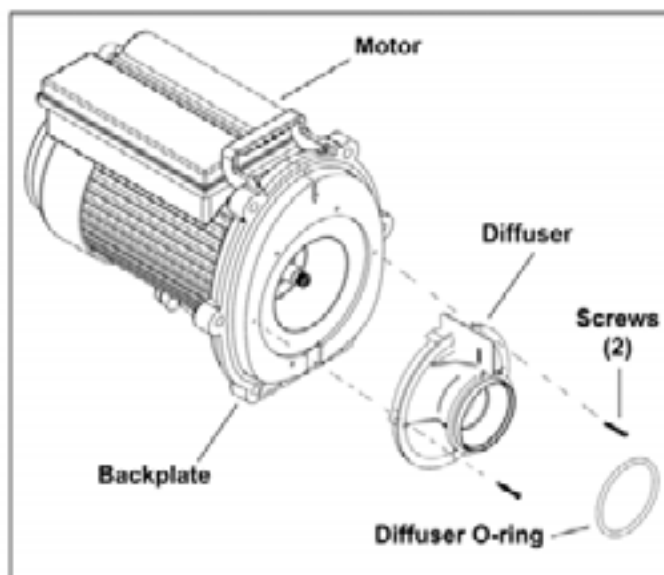

Figure 8. Remove the Diffuser



6. If necessary, remove any debris in the inlet and outlet of the impeller.
7. Remove the motor shaft cover on the back of the motor by twisting the hex-head screw with a 90° crescent wrench. (See Figure 7.) The motor shaft will be exposed.
8. Hold the exposed motor shaft with a ½" wrench and remove the impeller center screw using a No. 2 Phillips screwdriver. Turn the left-hand-threaded screw clockwise to loosen it. See Figure 9.

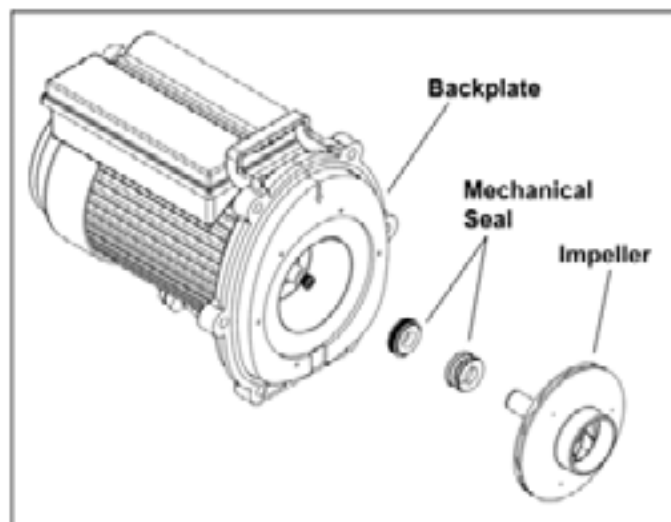

Figure 9. Remove the Impeller

9. Hold the motor shaft with a ½" wrench while unscrewing the impeller from the motor shaft with your hand. Turn the right-hand-threaded impeller counter-clockwise to unscrew it.
10. Inspect the impeller and diffuser for signs of rubbing and/or damage. See Figure 10.

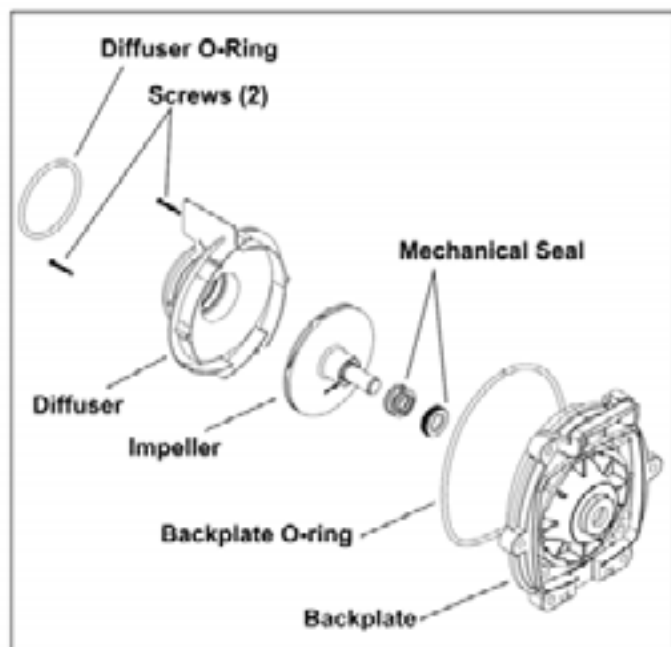

Figure 10. Diffuser and Impeller Exploded View

6.2.3 Impeller Replacement

⚠ WARNING

To avoid the risk of property damage, severe personal injury, or death, turn off the pump and switch off the circuit breaker to the pump motor before beginning this procedure.

1. Press the carbon face seal half (see Figure 11) on the motor shaft using a twisting motion. Make sure the carbon surface is facing toward the ceramic ring in the backplate.

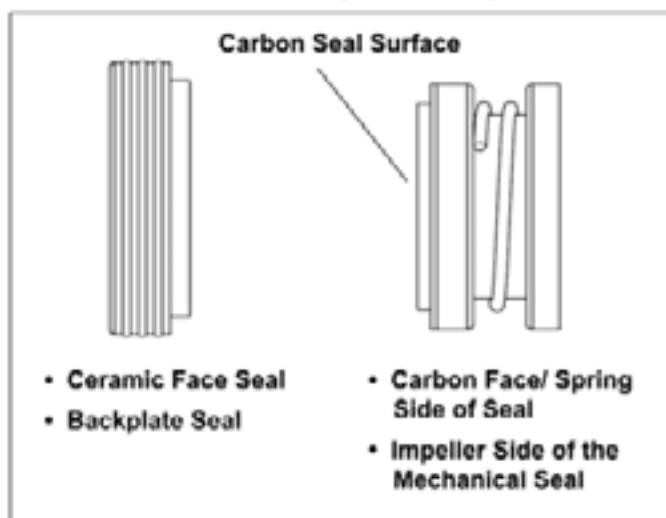

Figure 11. Mechanical Seal

CAUTION

VERY IMPORTANT! Grasp the lower portion of the seal (opposite the carbon face) when installing the seal or it will be damaged.

NOTE To assist assembly, **only** use water or a soap solution as a lubricant. Any other lubricant will destroy the seal after a short period of time.

NOTE Exercise great care to keep the seal and mating parts clean.

2. While holding the motor shaft with a ½" wrench, thread the impeller onto the motor shaft. Hand-tighten the impeller until it is secure. Install the impeller center screw into the center of the impeller and tighten, using a No. 2 Phillips screwdriver. **Do not overtighten.** Turn the left-hand-threaded impeller screw counter-clockwise to tighten it.
3. Replace the motor shaft cover by inserting the cover tabs into the slots and rotating the cover 90° clockwise.
4. Replace the diffuser over the impeller, using care to insert alignment pins into the correct holes. The alignment pins in the diffuser only allows the diffuser to be inserted only one (1) way.

5. Replace the two (2) small Phillips-head screws. Tighten the screws to draw the diffuser against the motor backplate.
6. Make sure the diffuser o-ring, o-ring groove, and o-ring seal area are clean and free of debris, which could cause a leak. If you removed the diffuser o-ring during disassembly, re-install it on the diffuser, as shown in Figure 12. If grease is used to retain the diffuser o-ring, it **must be silicone based**. Do not use petroleum-based grease. It will destroy the o-ring.

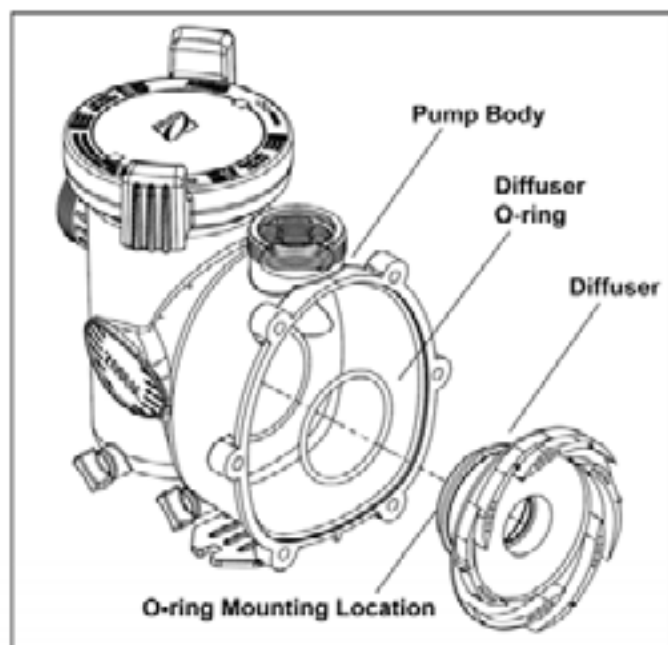

Figure 12. Pump Body and Diffuser Exploded View

7. Slide the diffuser into the mating hole in the pump body. While supporting the motor, start two (2) screws on opposite sides. (This will hold the motor in position while you start the other screws.) Start the other four (4) screws.
8. Tighten all six (6) screws lightly in a crossing "X" pattern using a 9/16" wrench. Start with the inner (middle) two (2), then tighten the outer (top and bottom) four (4) to draw the backplate to the body in an even manner.
9. If the pump is located above the water level of the pool, remove the lid and fill the basket with water before starting the pump.
10. Prior to replacing the lid, remove any debris around the lid o-ring seat, as debris will allow air to leak into the system.
11. Place the lid with locking ring on the pump housing. Align 'START' with the ports and turn the lid's locking ring clockwise until 'LOCKED' aligns with the ports. **Hand-tighten** the lid to make an air tight seal. **Do not use any tools to tighten the lid.**

12. Open the pressure release valve on the filter and make sure it is clean and ready for operation.
13. Switch on the circuit breaker to the pump motor.
13. Turn on the pump and check the system for normal operation.
14. Once all the air has left the filter, close the filter pressure release valve.

6.2.4 Mechanical Seal Replacement

NOTE Refer to Figure 13 for an illustration of the location of the mechanical seal and impeller.

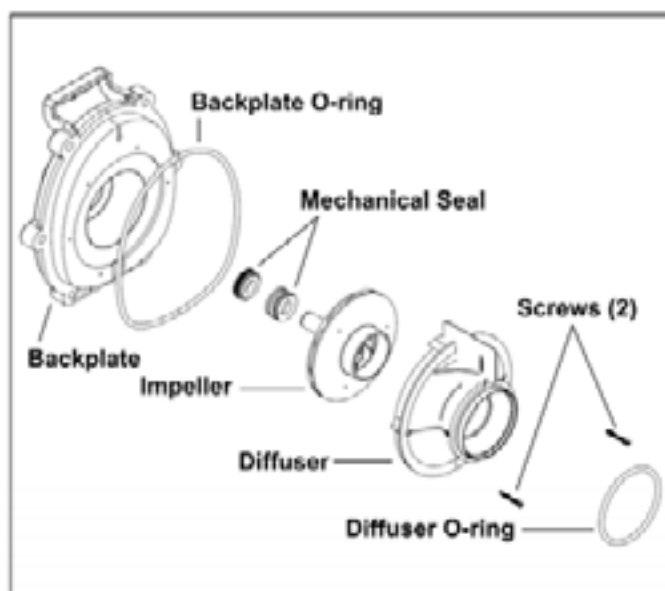

Figure 13. Backplate, Impeller, Diffuser, and Mechanical Seal Exploded View

NOTE This is a two-part replacement process. **The mechanical seal must be replaced as a set.**

WARNING

Do not damage the ceramic or carbon surfaces of the seals. If surfaces are damaged, leaks will occur.

1. To access the mechanical seal, comply with the warning and follow steps 1 through 8 of Section 6.2.2, *Impeller Removal*.
2. Remove the carbon face seal half from the motor shaft. (See Figure 11.) This is a spring-loaded seal. Grasp the portion of the seal closest to the impeller body and pull the seal off using a twisting motion.
3. Remove the motor from the backplate following steps 1 through 3 in Section 6.2.5, *Motor Replacement*.
4. Place the backplate o-ring side down and force the ceramic seal out using a screwdriver or drift.



5. Turn the backplate o-ring side up and insert the new ceramic seal side into the backplate. Use great care to press the seal in squarely with your fingers. The ceramic is easily damaged and must be pressed in using only your fingers or soft tools. Do not use any lubricant other than water and soap solution.
6. Install the backplate following the steps in *Section 6.2.3, Impeller Replacement*.
7. Install the motor following the steps in *Section 6.2.5, Motor Replacement*.

6.2.5 Motor Replacement

CAUTION

To ensure continued safety and reliable operation, Zodiac Group Australia Pty Ltd requires that you replace the motor with a motor that has the identical HP rating and service factor (Zodiac Pool Systems, Inc. approved only).

WARNING

To avoid the risk of property damage, severe personal injury, or death, turn off the pump and switch off the circuit breaker to the pump motor before beginning this procedure.

1. To disassemble the pump housing from the motor, follow steps 1 through 8 in *Section 6.2.2, Impeller Removal*.
2. Remove the four (4) screws on the main cover and remove the main cover.
3. Place the backplate motor assembly o-ring side down and unscrew the four (4) 9/16" screws and remove the motor.

NOTE Before removing the backplate, note the alignment of the backplate to the motor. See Figure 14.

4. If installing a new motor, remove the protective plastic cap from the motor shaft. Place the motor on the backplate so that the opening in the motor faces the bottom of the backplate. The starting capacitor on the motor should be at the 12 o'clock position.
5. Replace the four (4) bolts and washers holding the backplate to the motor.
6. To reassemble the pump after replacing the motor, follow steps 1 through 13 of *Section 6.2.3, Impeller Replacement*.

NOTE Zodiac Group Australia recommends replacing the mechanical seal at the same time that you replace the motor. See *Section 6.2.4, Mechanical Seal Replacement*, for details.

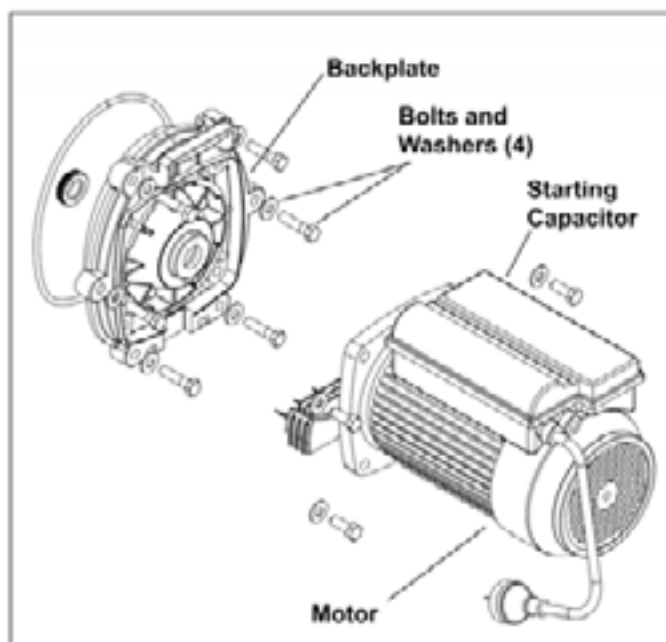

Figure 14. Backplate Assembly



Section 7. Product Specifications and Technical Data

7.1 Replacement Parts List

To order or purchase parts for Zodiac pumps, contact your nearest Zodiac dealer. If the Zodiac dealer cannot supply you with what you need, contact Zodiac customer service at 1800 688 552, or send an e-mail message to apac.aftersales@zmp-zodiac.com.

Key No.	Description	Model No. (HP)	Order Part No.
1	Motor & Hardware, WFHP	0.75 & 1.0	W131071A
1	Motor & Hardware, WFHP	1.5	W131081A
1	Motor & Hardware, WFHP	2.0	W131091A
2	Backplate, WFHP (Backplate w/Hardware, Backplate O-ring & Mechanical Seal)	All	W0479500
3	Impeller, WFHP (Impeller, Screw w/O-ring & Backplate O-ring)	0.75	W0479601A
3	Impeller, WFHP (Impeller, Screw w/O-ring & Backplate O-ring)	1.0	W0479602A
3	Impeller, WFHP (Impeller, Screw w/O-ring & Backplate O-ring)	1.5	W0479603A
3	Impeller, WFHP (Impeller, Screw w/O-ring & Backplate O-ring)	2.0	W0479604A
4	Diffuser, WFHP (Diffuser w/O-ring, Hardware & Backplate O-ring)	All	W0479701A
5	Mechanical Seal, Carbon & Ceramic (1 Set)	All	W0479400
6	Pump Body, WFHP (Body and Backplate O-ring)	All	W0479800A
7	Motor Mounting Foot, WFHP	All	WA0133001
8	Lid w/Locking Ring, WFHP (Lid w/Locking Ring & Lid O-ring)	All	W0480000
9	Pump Debris Filter Basket, WFHP	All	WA0130900
10	Drain Plug w/O-ring, WFHP	All	W0446000A
11	Tail Piece, O-ring & Union Nut	All	W0327301
12	Lid O-ring, WFHP	All	WS0137200
13	Backplate O-ring, WFHP	All	WS0137300
Not Numbered	Diffuser O-ring, WFHP	All	WS0119000
14	Diffuser/Impeller Hardware (Diffuser O-ring, Screws (2), Screw w/O-ring & Backplate O-ring)	All	W0480400
15	Backplate Hardware, WFHP (Backplate Hardware & Backplate O-ring)	All	W0480500
16	Motor Hardware Kit	All	W0446700
17	Tailpiece O-ring	All	WS0104900

7.2 Exploded View

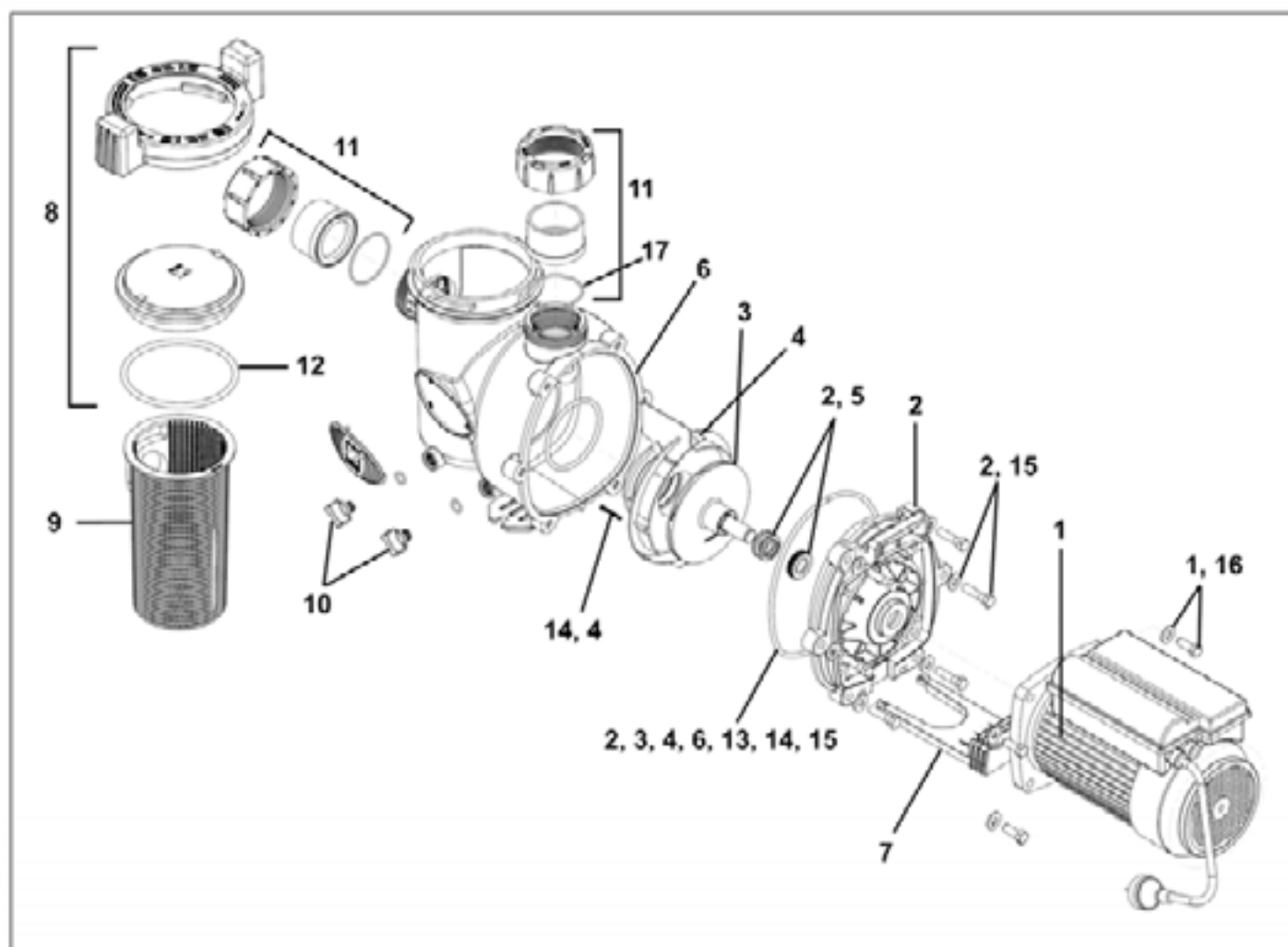
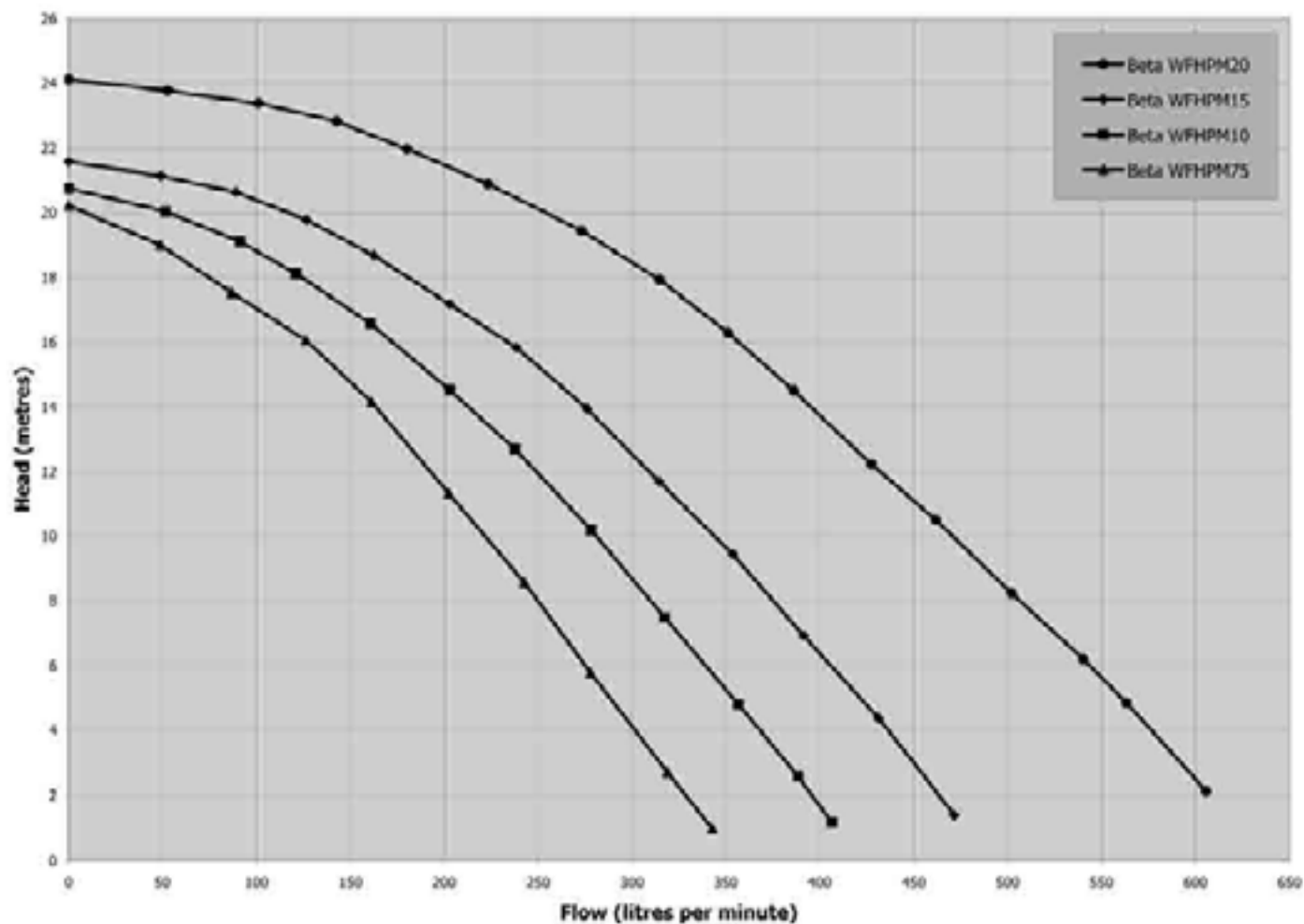

Figure 15. FHP Exploded View

7.3 Performance Curves

Australian Pump Comparisons: WZEP Alpha & WFHP Beta Family



WFHPM20 - 24 metres

WFHPM15 - 21.5 metres

WFHPM10 - 21 metres

WFHPM75 - 20 metres



7.4 Physical and Operational Specifications

7.4.1 Specifications

Model No.	HP	Voltage	Amps	Pipe Size	Carton Weight	Overall Length 'A'
FHPM .75	0.75	240/115	5.4/10.8	40 - 50mm	40.6	625mm
FHPM 1.0	1.00	240/115	7.1/14.2	50mm	41.2	625mm
FHPM 1.5	1.50	240/115	8.0/16	50mm	42.6	625mm
FHPM 2.0	2.00	240/115	11.2/22.4	50mm	54.6	625mm

Figure 16 shows the dimensions (height, width, and length) of the FHP pump without the FHP base and spacers.

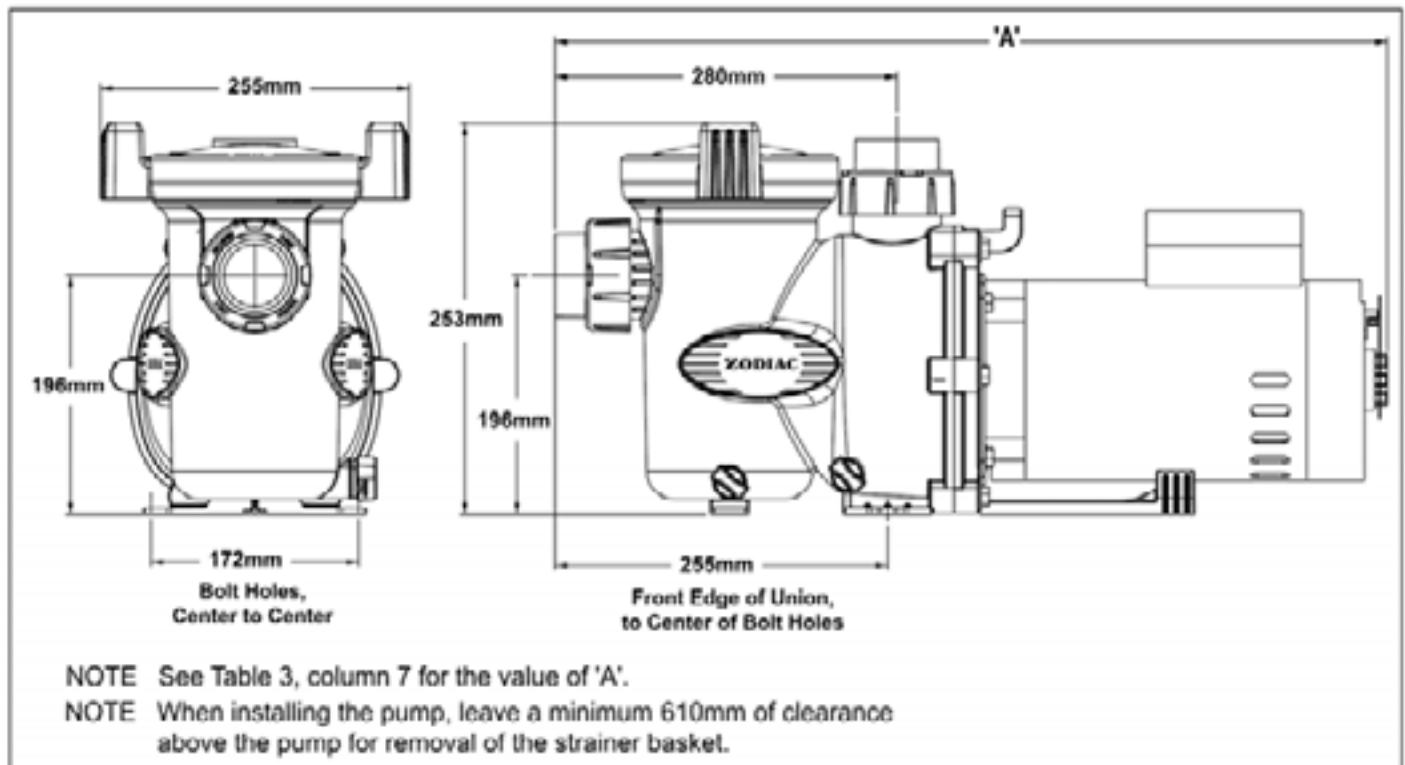

Figure 16. FHP Pump Dimensions (without Base or Spacers)

Zodiac FloPro Pool Pump Warranty

This Zodiac FloPro Series pool pump was carefully inspected before shipment from our warehouse. Upon unpacking, if any part is missing or found to be defective, please notify your dealer immediately.

Zodiac Group Australia Pty Ltd warrants the FloPro Series pool pump to be free from defects in materials and workmanship for a period of 3 years from date of purchase and 1 year on the mechanical seal for domestic applications. The warranty is applicable to the asia pacific region only.

This limited warranty excludes the following:

- 1) Replacement of parts which fail or become defective as a result of improper installation, negligence, misuse, abuse or tampering by unauthorized personnel.
- 2) Lightning or other acts of nature
- 3) Damage or malfunction of the unit resulting from improper water chemistry balance.
- 4) Scaling, freezing, or other conditions causing inadequate water circulation
- 5) Normal wear and tear
- 6) Inadequate ventilation
- 7) Running the pump dry
- 8) The use of non-factory authorized parts or accessories in conjunction with the product(s)
- 9) Operating the product(s) at water flow rates outside the published minimum and maximum specification.

To obtain warranty replacement or repair, the unit should be returned to the place of purchase. When submitting a claim, always supply serial number, evidence of purchase date, retailer and brief description of the problem/ defects encountered. Zodiac Group Australia Pty Ltd reserves the right to repair or replace all defective or worn parts covered by this warranty, through the place of purchase. Where the purchaser sends the units to the place of purchase by post or courier for repair or replacement, freight is the responsibility of the purchaser.

Zodiac and/or its authorized service centres may seek reimbursement of any costs incurred by them (including labour charges) when the product or relevant part is found to be in good working order or if the warranty claim is invalid.

Zodiac Group Australia Pty Ltd assumes no responsibility for any warranties or representations made by other individuals or businesses beyond the express terms contained in this limited warranty.

The warranty gives you specific legal rights, and you may also have other rights which vary from state to state. This warranty will remain the property of Zodiac Group Australia Pty Ltd.

Commercial Applications

The Zodiac FloPro series pool pump is warranted for a period of 12 months for all parts from the date of the first consumer purchase. Should any parts fail as a result of such defects within the 12 month period, Zodiac will warrant it free of charge. Any associated travel charges are not included.





ZODIAC



Zodiac is a registered trademark of Zodiac Group Australia Pty Ltd
ABN 87 002 641 965

ZODIAC CUSTOMER SERVICE CENTRE

Zodiac Group Australia:

219 Woodpark Rd, Smithfield,
NSW 2164 Australia

Tel: 1800 688 552

Fax: 1300 781 688

Email: aftersales@zodiac.com.au

www.zodiac.com.au

Due to constant developments and improvements,
specifications may change without notice.
Improper use could affect performance and void warranty.

© Copyright Zodiac Australian Ltd 2009